

Eco 250esm / 300esm / 280i / 200p

Assembly and User Manual



Thermodynamic Solar System

INDEX

1. Important	3
2. Operating Procedures	3
3. Description	4
4. Technical Specifications	5
4.1. Thermodynamic Solar Panel	5
4.2. Hot Water Cylinder	5
4.3. Thermodynamic Block	6
4.4. Fluid, R134a	6
4.5. Safety Group	7
4.6. Expansion Tank	7
4.7. Pressure Reducing Valve	7
5. Installation	8
5.1. Panel Fixation	8
5.2. Hot Water Cylinder Installation	9
5.3. Installation of the Thermodynamic Block	9
5.4. Connections	10
5.5. Nitrogen Load	12
5.6. Vacuum	12
5.7. Fluid Load	12
5.8. System Start-up	13
5.9. System Decommissioning	13
6. Anomalies / Causes / Solutions	14
7. Maintenance Procedures	15
8. ANNEXES	16
Technical Schematics	17
Electrical Schematics	21

1. IMPORTANT



The Eco shall only be started if the hot water cylinder is fully filled with water.

The Eco can only function after the respective refrigerant supply has been connected.

The electrical input is: ~230 V, 50 Hz.

2. OPERATING PROCEDURES



Please read the following instructions before start installing or operating with the solar system.

The Thermodynamic Solar System Eco shall only be used for the heating of fresh water and at the limits indicated on temperature application! Heating of other liquids, such as industrial waters or others, shall not be made with this solar system. The technical rules (DIN 1988) for the supply of fresh water must be taken into account.

The thermodynamic solar panel shall be positioned:

- Outside;
- In a place with good solar capture;
- Respect fixing/fastening rules.

Positioning of the hot water cylinder must not be done in:

- The open air;

- In spaces that are potentially explosive due to vapour or liquid gases.

Do not turn on the solar system:

- With an empty hot water cylinder;
- Without fluid supply (R134a).

The Eco must always be voltage free when being worked on.

- Eco construction and assembly procedures comply with the relevant EC directives.



VDE, EN and IEC standards must be complied with when making electrical connections to the Eco.

Installation, assembly or maintenance of Eco thermodynamic solar system may only be carried out by qualified personnel!

2.1 PACKING, STORAGE & TRANSPORTATION

All Energie – Thermodynamic Solar Systems products are to be kept in the original packaging materials and should be stored or transported in the vertical position - note there is an arrow to indicate the 'UP' direction for packing's.



European Certification EN 60335-1 EN 60335-2-21 Directives 73/23/CEE 93/68/CEE

3. DESCRIPTION

The Eco solar system is equipment based on the Carnot principle compression/refrigeration principle, denominated as a Thermodynamic Solar System.

The solar panel is the main component and shall be placed outside for the capture of:

- Direct and diffuse Solar Radiation;
- External air, by natural circulation;
- The effect of wind (almost always existent);
- Rain

The differences between temperatures, stimulated by the previously described agents, guarantees that Klea (ecological refrigerant fluid) evaporates in the solar panel's interior. The absence of glass in the panel allows for increased thermal exchange by convection.

After passing through the panel, the Klea fluid is aspirated by the system's mechanical component, the compressor, which in turn raises the temperature and pressure; it is then transmitted to the water circuit via a heat exchanger.

Before the Klea fluid returns to the solar panel it is necessary for a throttling process occurs, in other words, pressure reduction that guarantees the liquid state is once again achieved, completing the overall cycle.

This operational process, in which we ally technology with the laws of nature (changing states of a liquid), demonstrates the power and the potential of the Eco system.

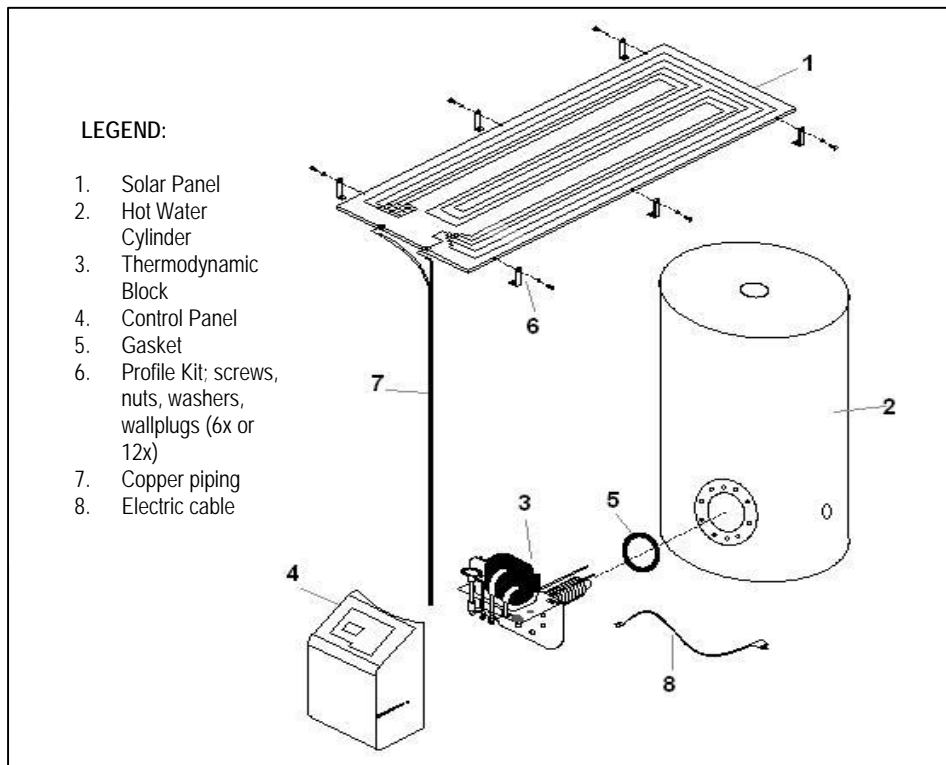

Fig.2 Overall View of the Equipment Components

4. TECHNICAL SPECIFICATIONS

The thermodynamic solar system Eco is composed by the following components:

- Thermodynamic Solar Panel
- Hot water cylinder
- Thermodynamic Block
- Control Panel
- Pressure reducing valve
- Security group
- Brackets, screws, female, washer, bushing (6x)

4.1 Thermodynamic Solar Panel

The thermodynamic solar panel is made of anodized aluminium with corrosion protection.

There are two different types of solar panels: left and right ones (named by the position of the connections). Although they are aluminium made, shall be handle with care.

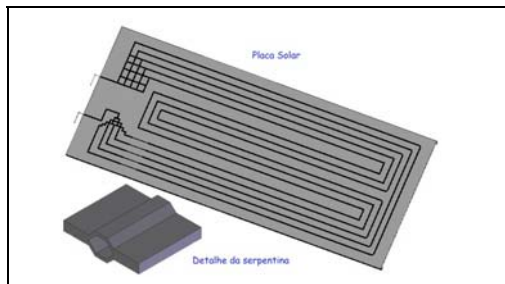

Thermodynamic Solar Panel	
Width	2000 mm
Height	800 mm
Thickness	20 mm
Weight	8 kg
Gross Area / Absorber Area	1,6 m ²

Tab 1. Solar panel dimensions

The connections to the panel are Flare SAE (screw) types:

- 3/8" Aspiration (upper connection)
- 1/4" Liquid (lower connection)

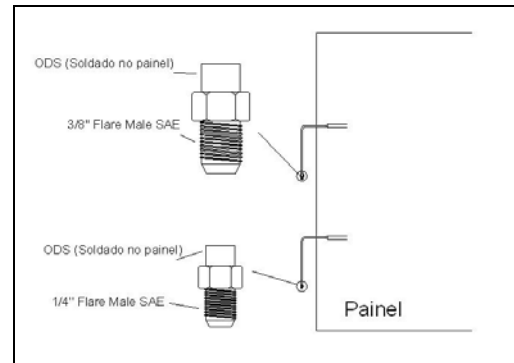

Fig. 4 Panel Connections

4.2. Hot water cylinder

Hot Water Cylinder			
	250esm	300esm	280i
Height (mm)	1500	1580	1650
Diameter (mm)	584	680	550
Weight (kg)	85	93	40

Tab 2. Hot water cylinder dimensions

4.2.1. Eco 250esm / 300esm / 280i

The hot water cylinder is vertical and shall be installed that way. It is made of stainless steel and is thermal insulated with 42 mm polyurethane.

The hot water cylinder is equipped with a cold-water inlet, hot water outlet, recirculation inlet and a magnesium anode.

There is a flange type opening in the bottom of the hot water cylinder for placing the thermodynamic block.

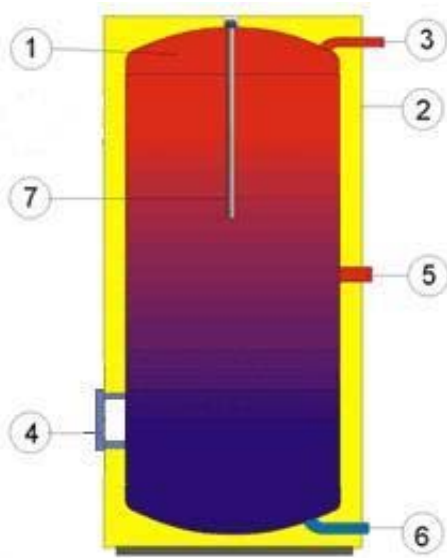

Fig. 5 Hot water cylinder

- 1 – Enamelled / Stainless Steel
- 2- Outside coating
- 3- Hot water outlet
- 4- Flange
- 5- Recirculation inlet
- 6 – Cold water inlet
- 7- Magnesium anode

4.3 Thermodynamic block

We call Thermodynamic Block to the component that transfers the Energy caught by the solar panel in heat transferred to the water.

Thermodynamic Block	
Height	650 mm
Width	310 mm
Depth	300 mm
Weight	15 kg
Power Input	390 - 550 W
Power Output	1690 -2900 W
Fluid , R134a	550 g

Its structure is made of galvanized steel that has the compressor, heat exchanger, expansion valve, thermostat, pressure switch, electric resistance.

The front part of the block has two valves, of 2 and 3 ways destined for the panel connections (3/8" - Aspiration; 1/4" - liquid)

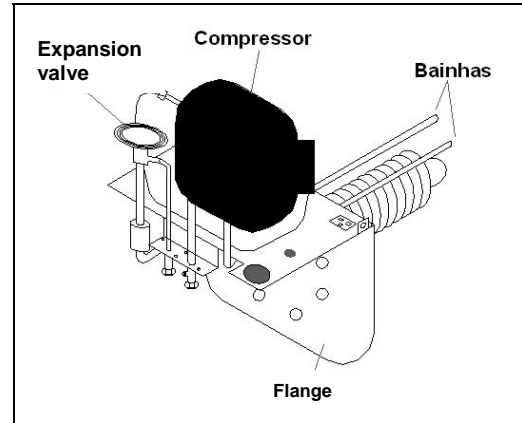

Fig. 6 Thermodynamic Block (main components)

The Thermodynamic Block is connected to the hot water cylinder through eight M10 screws.

4.4 Fluid, R134a

R134a is an ecological fluid that is not harmful to the ozone layer. It has a high thermal and chemical stability, low toxicity, is non-flammable and is compatible with the majority of materials.

PRESSURE/TEMPERATURE GRAPH

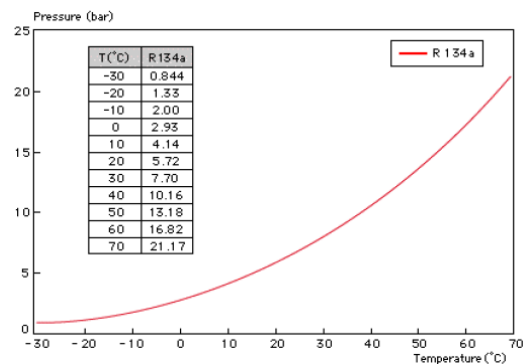

4.5 Safety Group

The safety group enables the system to be protected against situations such as; anomalies in the supply of cold water, the

return path of hot water, emptying of the hot water tank and raised temperatures. It is a valve body made out of chromed brass, in accordance with European ISO 9001 standards. The valve is calibrated to open at 7 bar.



Fig. 6 Safety Group

1. Threaded orifice (3/4") for direct connection to the hot water cylinder.
2. Threaded orifice (3/4") for the input of cold water.
3. Security valve discharge orifice, with opening (1").
4. Feed Valve.
5. Security valve discharge device command.
6. Inspection lid.

4.6 Expansion Tank

The expansion tank is a device designed to compensate for any increase in water caused by a rise in temperature.



This is the recommended procedure for the correct installation of this equipment.

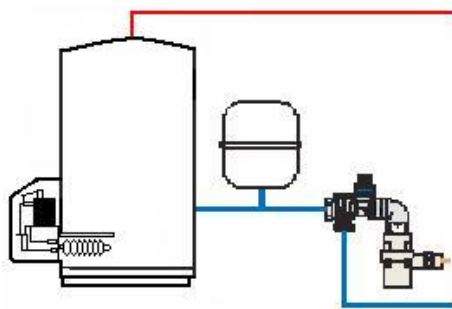

Fig. 7 Expansion tank installation diagram

NOTE:

Installation of the expansion tank is the responsibility of the installer. It can normally be installed into the cold water or hot water piping system.

4.7 Pressure Reducing Valve

The pressure reducing valve must always be installed upstream from the safety group and be ready to operate in situations in which the network pressure rises to above 3 bar. This valve comes equipped with a manometer.



Fig. 8 Pressure reducing valve

Characteristics:

- Chromed Brass Body
- Max. upstream pressure: 16 bar.
- Downstream pressure 1 – 6 bar.
- Max. operating temperature: 65° C
- Manometer: 0 to 10 bar
- 3/4" Threaded orifice (entry and exit).

5. INSTALLATION

Assembly Sequence

- Solar Panel(s)
- Hot Water Cylinder
- Thermodynamic Block
- Refrigerating connections (suction, liquid)
- Hydraulic connections
- Electrical connections
- Nitrogen supply
- Vacuum
- Installation start-up

5.1 Panel Fixation

It is important to take the characteristics of the installation location and the inclination angle of the panels into account. In order to get maximum benefit from incidental Solar Radiation, the panels must be at an inclination of between 10° - 85° in relation to the horizontal position, preferably orientated towards the South.

It may be installed in a wall, façade, roof, plain roof or other.

The panel comes already supplied with 6 M8 screws on the lateral tabs. The distance between the holes in the location where the panel is to be fixed must coincide with the panel holes (Fig. 13):

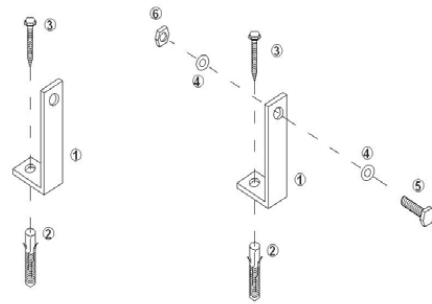

Fig. 9 Profile fixing diagram

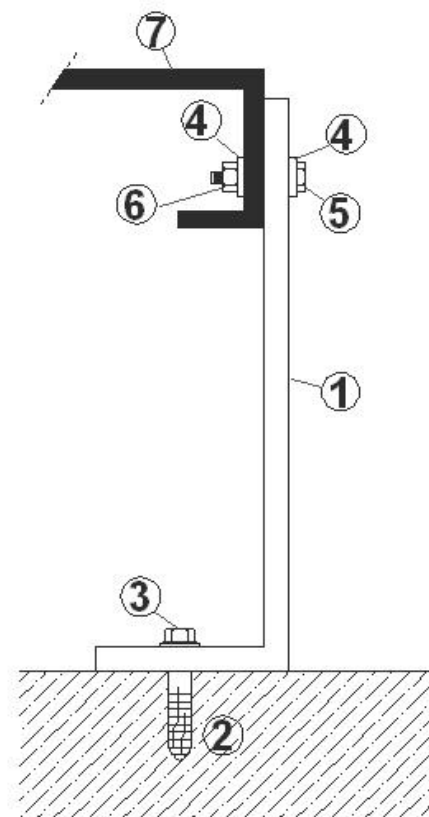

Fig. 10 Panel profile fixing process

1. Profile (aluminium)
2. Plastic wall plug
3. Self-tapping screw (M6x40)
4. Washer M6
5. Screw (M6x20)
6. Nut M6
7. Panel

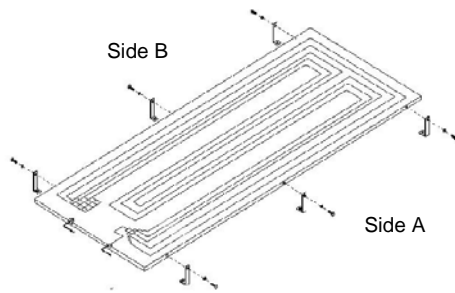

Fig. 11 Panel fixing diagram

The system comes with six sets of: profiles, screws, nuts, washers, wall plugs.

The panel has 3 small profiles (side A) and 3 large profiles (side B) which shall be fixed according stipulations in the diagram, giving the panel the desired level of inclination.

The profile shall be fixed to a base (e.g. a roof) via the provided plastic wall plugs and the self-tapping M6 screws.

The M6 screws and the respective nuts and washers shall make the panel fixing to the profiles.

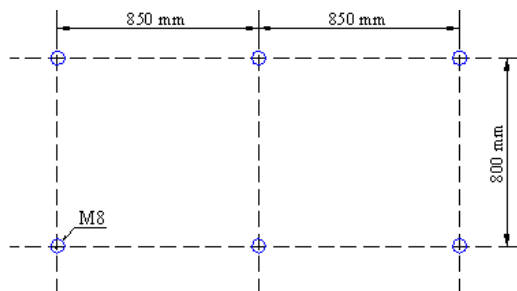

Fig. 12 Panel hole drilling diagram

The solar panel shall always be installed with the connections facing downwards.

Refer to the 2 existing different types of panels; right panels (A) and left panels (B).

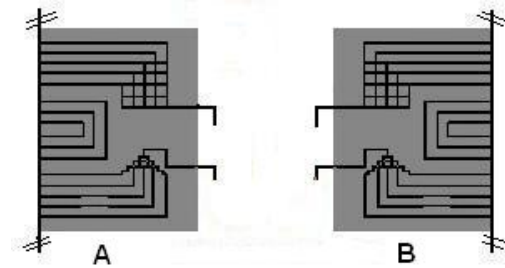

Fig. 13 Panel types (left and right)

5.2 Hot Water Cylinder Installation

The hot water cylinder shall be installed in a cool and dry location with easy access and protected from all weather conditions. The choice of location must allow for easy assembly of the Thermodynamic Block.

i The spot where the hot water cylinder shall be installed must have nearby:

- A cold water point
- Hot water point
- Drainage.
- Recirculation (if it exists).
- Electrical point, 230 V/50Hz



AVISO !

Observe that in some hot water cylinders the hydraulic connections are at the back of the device, it hence being necessary to consider the spacing between them and the wall.

5.3 Installation of the Thermodynamic Block

Before installing the Thermodynamic block, make sure that the heat exchanger is not in contact with the resistance casing and the thermostat. To check this, use a multimeter (in the continuity position), positioning a connector on the heat exchanger and the

other on the block's support structure (compressor or flange) and verify that no continuity actually exists.

- The Thermodynamic Block is coupled into the existing flange (at the lower part of the hot water cylinder).

- Correctly place the sealing gasket before tightening up between the flanges.

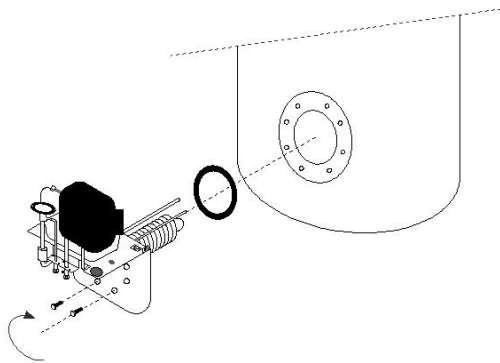

Fig. 14 Coupling of the Block to the hot water cylinder

- Place the heat exchanger into the hot water cylinder, taking special care upon its placement, avoiding any damage.

- The coupling of the Thermodynamic Block to the water cylinder shall be done with the supplied screws. Tightening of the screws must be done with a crosshead screwdriver, guaranteeing air-tightness.

The hot water cylinder shall be properly fixed in place at the moment the Thermodynamic Block is positioned, thus avoiding any slight drop in the unit, considering that there will be a centre of gravity dislocation.

5.4 Connections

The copper tubes used to connect the thermodynamic block to the solar panel shall be refrigerant type without sewage (Type Cu

DHP according to the ISO1337 standards and EN12735).

Piping Diameters			
GAS (aspiration)		LIQUID	
mm	inches	mm	inches
9,52	3/8"	6,35	1/4"

Tab 4. Piping diameter (aspiration and liquid)



In any circumstance shall be used sanitary water copper tubes.

Panel Connections

Take off the covers of the copper pipes ends. Place the extremity of the pipe turned down and cut the pipe at a distance intended. Remove the existing barbs.

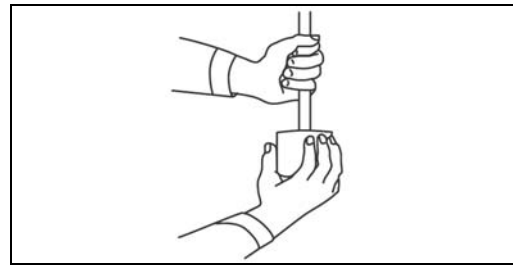

Fig. 16 Barbs removal

Remove the connections nuts from the panel and place them aside of the pipe. Make a conical shape at the end of the pipes with an appropriate tool.

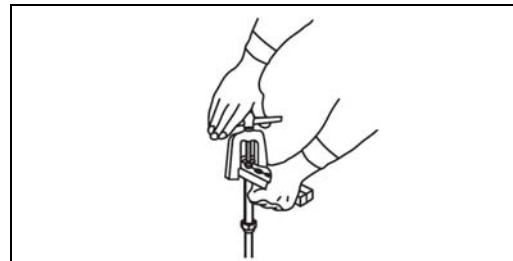

Fig. 17 Conical shape

The conic must not have any barbs or imperfections. The longitude of the walls of the conic one must be uniform.

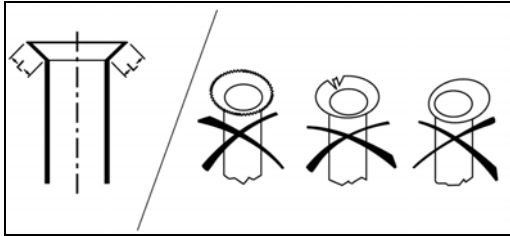

Fig. 18 Correct conic shape

Place the nut with the hand and then rotate it with two keys that shall be applied like torsion pair, as the figure indicates.

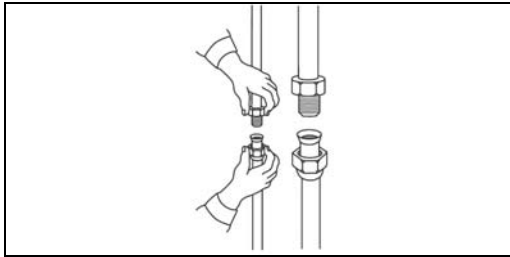

Fig. 19 Tight the connections

An insufficient tightening will cause gas to escape. An extreme squeeze of the coupling will damage the pipe and will cause the gas to escapes.

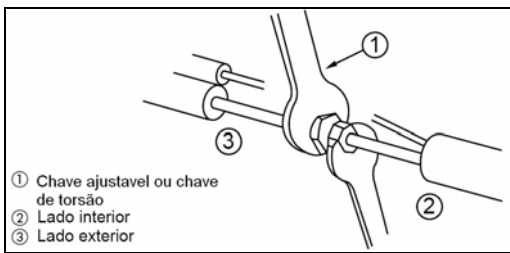

Fig. 20 Tightening with proper keys

Pipe diameter		Torsion Nm
mm	(inches)	
6,35	(1/4")	14 -18
9,52	(3/8")	33 - 42

Tab.5 Tightening

After finished the connection, it must prove that no gas escape exists by applying soap foam on the connections (with nitrogen load on).

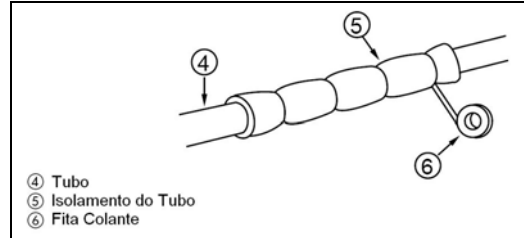
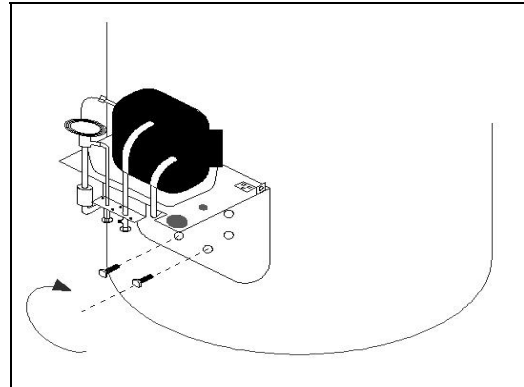

Fig. 21 Connection Thermal Protection

Thermodynamic Block Connection

After the installing of the thermodynamic block to the hot water cylinder with the 8 M10 screws, the connections shall be made



Repeat the procedure used to connect the panel to the copper pipes.

Cut of the pipe in the required length with the extremity directed towards down. Clean the existing barbs. Before making the conic shape in the pipe, do not forget to place the nut in the pipe.

The entrance of piping into the building shall be finished to guarantee total resistance against rain and moisture.

The piping must be properly insulated with a flexible insulation sleeve made from (Armaflex type) elastomeric foam in order to prevent any possible condensation brought about by low temperatures in the liquid.

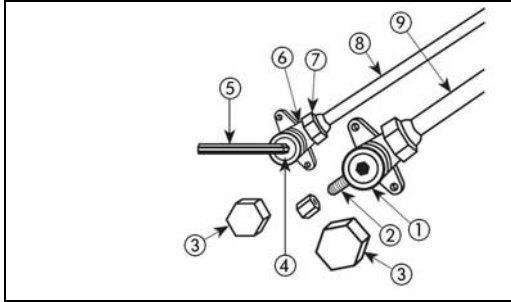

Fig. 23 2 and 3 ways valves details

- 1- 3 way valve
- 2- Pressure Inlet
- 3- Valve Bush
- 4- Valve rotor
- 5- Hexagonal Key
- 6- 2 way valve
- 7- Conical Nut
- 8- Liquide Line (smallest diameter)
- 9- Gas line (bigest diameter)

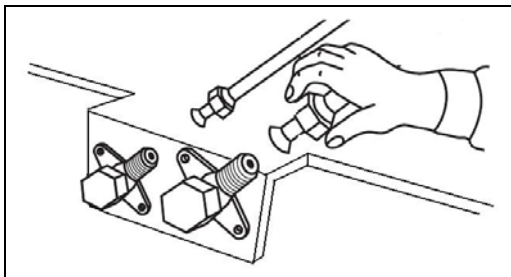

Fig. 24 Connecting the pipes to the thermodynamic block

Press the nut with the hand by giving some turns, and apply the pair of keys like seen before.

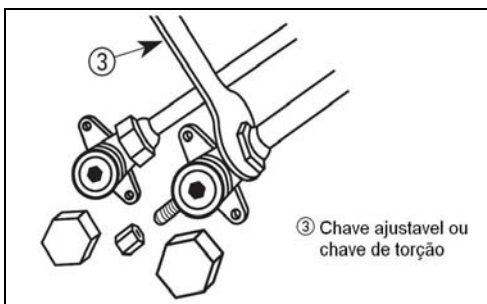

Fig. 25 Tightening the tubes to the valves

5.5 Nitrogen Load

After connections been concluded guarantee that there is no leakage. The nitrogen load must be done through the 3 ways valve until the pressure reaches 12 bar.



Place all the connections under soap foam and verify if the pressure is kept constant.

5.6 Vacuum

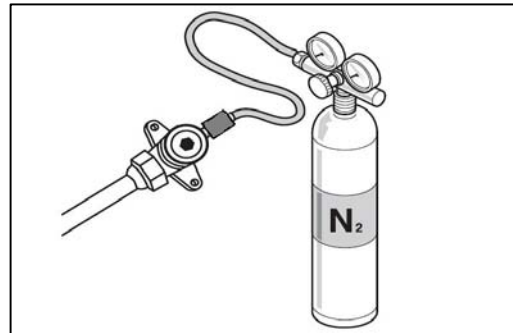

Fig. 26 Nitrogen pipes and panel load



Use only the vacuum pump to remove the air and the humidity from the pipes.

Never use the gas to extract the air or the humidity from the pipes. That will reduce the life of the compressor drastically.

All the valves shall be turned off before the vacuum is start being made. This way the vacuum will only be done inside the tubes.

5.7 Fluid Load

After carried through the vacuum process the two valves shall be open for the fluid circulate all in the system. To enhance that the system is supplied with a pre-load that is enough for a maximum length of 10 meters

between the solar panel and the thermodynamic block. For situations that this length is exceeded it is necessary to have to make adjustments of the load. These adjustments shall be done by the compression pipe with the system stopped.

5.8 System Start-up

The Eco commissioning is assured by the correct installation achieved and by the respect of all installation instructions. Increasing water temperature from 10° C to 55° C will vary between 4 to 8 hours, depending on weather conditions and type of installation.

It is always possible to do a tune of thermal expansion valve to adapt the system to a suitable outside weather conditions by the temperatures extrapolation method.

Fill the hot water cylinder with water and purge the existing air, opening a hot water tap/faucet.

Check if the valves are properly working and if the system is filled with fluid.

There aren't any failure problem when starting the system under frost conditions.

To conclude the installation process it is necessary to connect the electrical cable to the 230V plug socket, securing the control panel with two M6 screws.

To turn the apparatus on, press the general ON/OFF button (1) on the control panel. Afterwards, press the ON/OFF button on the Solar System (2). The display must give information that the system is operational (ON). Heating up of the water will now begin.

The Eco is equipped with an electrical resistance heating process in case of any eventual system breakdown. If it is necessary to use this function, press the Electrical Support (3) ON/OFF button on the command panel and the water will be heated via electrical resistance.

5.9 System Decommissioning

At the end of the product lifetime, decommissioning of the system should be undertaken by an installer or suitable qualified plumber and / or electrician (if required). All materials used in this product can be passed to your local material recycling centre for disposal - refer to local council regulations for details.

6 CONTROL PANEL

You may start up the Eco if all instructions have been accomplished. The rise up of the water temperature from 10°C to 55°C may vary between 2 and 10 hours depending on the model of the solar system and the outside conditions.

The command panel is an interface between the user and the equipment and you may have information about the working of the solar system.

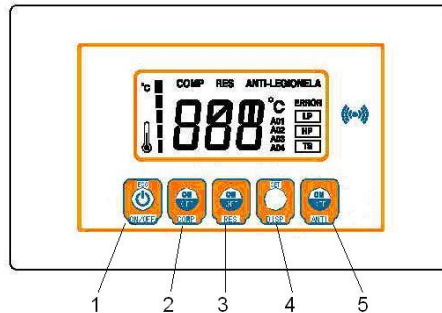





Fig. 23 Control Panel

N°	Button	Name	Function	Display
1		ON/OFF Button	Allows the user to switch power ON or power OFF. If you press this button the display present the following information:	
2		ON/OFF Button for the Solar System	Works for turning the power ON/OFF only for the compressor. It has a one-minute delay before turning the system OFF, between that time the word ON will blink on the screen.	
3		ON/OFF Button for Electrical Backup	This shall only be turned on an emergency situation to ensure hot water to the user in case of a system malfunctioning.	
4		Programming Button (Factory Only)	This allows the modification working parameters. Do not use this unless you are a trained technician otherwise you could damage the solar system that will result in guarantee lost.	
5		Anti-Legionella Button	Activate the anti-legionella program. This will rise up the temperature of the water until 65°C. Only turn ON this program if you do not predict to have any water consumption on the next 8 hours.	

Legend

- a- Temperature
- b- Output ON
- c- State of the System (OFF, ON, ALM)
- d- Errors
- e- Factory Parameters

7 ANOMALIES / CAUSES / SOLUTIONS

ANOMALY	CAUSE	SOLUTION
The water is cold and the compressor does not function. <i>(Display shows no information)</i>	System turned off	Verify the presence of 230 V A/C at system input source. Check that the system is turned on. Make sure electrical cabling is not disconnected.
The water is cold and the compressor does not function. <i>(Display shows no information)</i>	Protection system activated Condenser is covered with lime	Check electrical protection (the Fuse). Check for Low Pressure breakdown ("LP" Error). Carry out effective cleaning.
Cold or lukewarm water, but compressor is functioning.	Excessive water consumption Alteration in electronic parameters Refrigerant fluid leakage	Wait for Thermal Charging to occur. Substitute the electronic panel. Detect and repair the leak.
The compressor periodically stops and starts	Badly connected voltage input Refrigerant fluid leakage Condenser is covered with lime	Check voltage feed (230 V). Detect and repair the leak. Carry out effective cleaning.
The display do not present any information	Lack of power Safety thermostat ON	Check if there is power supply. Check the electrical cables connection for the control panel. Check the system fuses. Rearm the safety thermostat
LP Error on display: 	Fluid missing in the solar panel circuit Outside temperatures too low	Turn ON the electrical backup if needed. Every time that a LP error occurs the system will have a 20 minutes delay, during that period the word "ON" shall blink in the screen.
The display presents the word: 	Solar system is shut down	Press the ON/OFF button for the solar system
The display presents the following information but the water is cold: 	Power supply malfunction Excess of water usage	Check the fuses. Wait for the water to warm up

Technical Support Notes:

- Melted Compressor fuse; start-up condenser capacity must be checked.
- Melted RES fuse; the possibility of a short-circuit must be verified (e.g. electrical resistance).
- Safety thermostat operational; electronic panel parameters must be checked.

8. MAINTENANCE PROCEDURES

Magnesium Anode

The anode must be removed in order to check its state.

If the magnesium anode is letting water pass it will be necessary to change it. The period between changing the anode is always dependent of the water quality in each location. In areas with raised concentrations of soluble solids, the anode needs to be changed with less regularity, whereas in situations with low concentration, the anode needs to be changed with greater regularity. Therefore the magnesium anode state shall be checked at least one time per year.

Pressure Reduction Valve Filter

The following procedure shall be done for periodic (maximum once every two years) cleaning of the pressure reduction valve filter:

1. Close the passage of water from the network.
2. Turn in an anti-clockwise direction after relieving the spring's tension.
3. Draw back the lever/handle.
4. Remove the filter and clean it.

9 TECHNICAL DATA

System	Eco 250esm / 300esm	Eco 280i / 200p	UNITS
Potential Data			
Thermal Power	1690 – 2900		W
Absorbed Power	390 – 550		W
Electric Support Power	1200		W
Compressor			
Type	Hermetic / Piston		
Noise Level	39		dB
Thermodynamic Solar Panel			
Material	High Performance Anodised Aluminium		
Quantity	1		
Dimensions	2000 x 800 x 20		mm
Max. operating pressure	12 / 1,2		bar / Mpa
Test pressure	15 / 1,5		bar / Mpa
Max. Temperature	120		°C
Min. Temperature	- 5		°C
Min, Exposure Temperature	- 40		°C
Hot Water Cylinder			
Material	Enamelled	Stainless Steel	
Insulation	Polyurethane		
Max. working pressure	6 / 0,6		bar / Mpa
Test pressure	10 / 1,0		bar / Mpa
Max. Operating Temperature	90		°C
Protection	Magnesium Anode		
Fluid			
Type	R134a		
Quantity	1100		kg
Connections (piping)			
Type	Copper		
Liquid Line	1/4"		inch
Aspiration Line	3/8"		inch
Electronic Panel			
Feed	230 / 50		V/Hz
Compressor Fuse	6.3 T		A
General Fuse	6.3 F		A

10 DIMENSIONS AND TECHNICAL SCHEMATICS

Eco 250esm

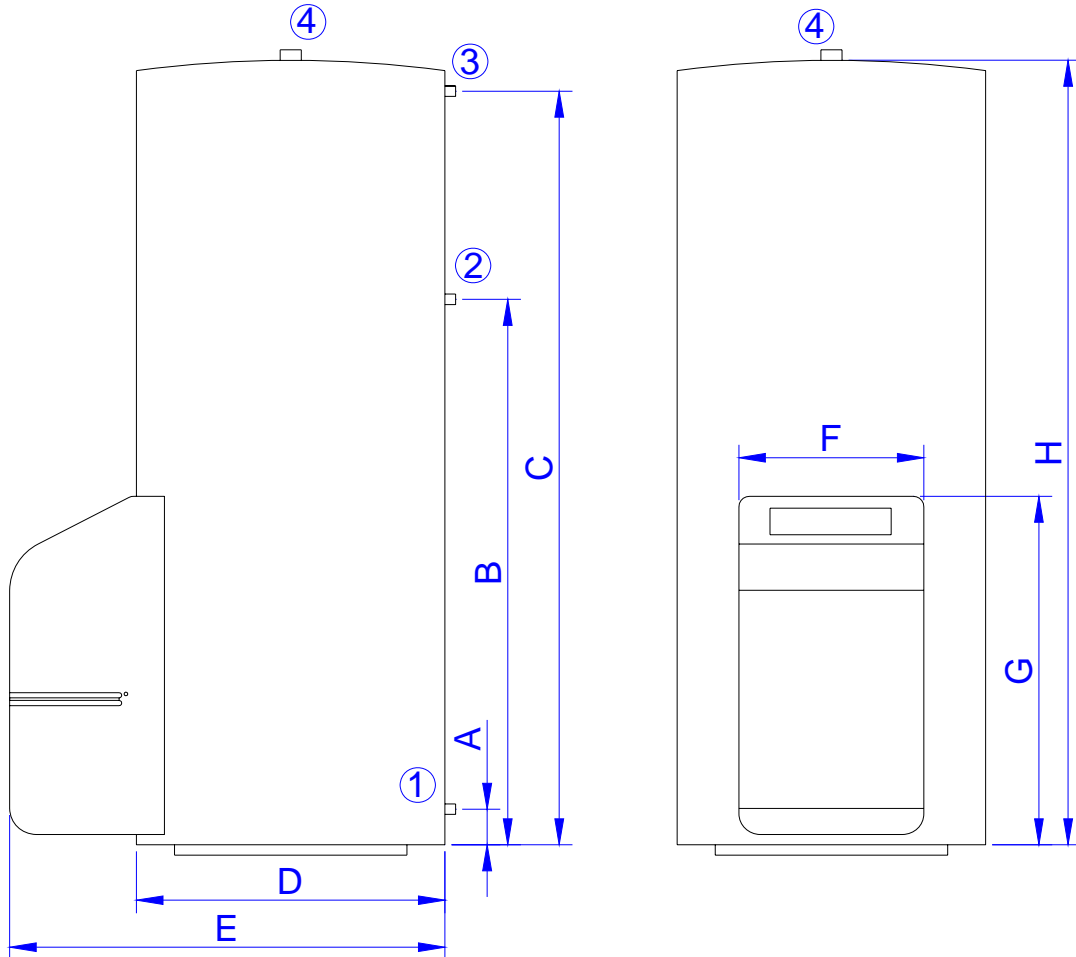

- 1- Cold water inlet
- 2- Recirculation
- 3- Hot water outlet
- 4- Magnesium anode

A	B	C	D	E	F	G	H	1	2	3	4
mm								inches			
70	1050	1450	584	820	350	800	1500	3/4"	3/4"	3/4"	5/4"

Eco 280i

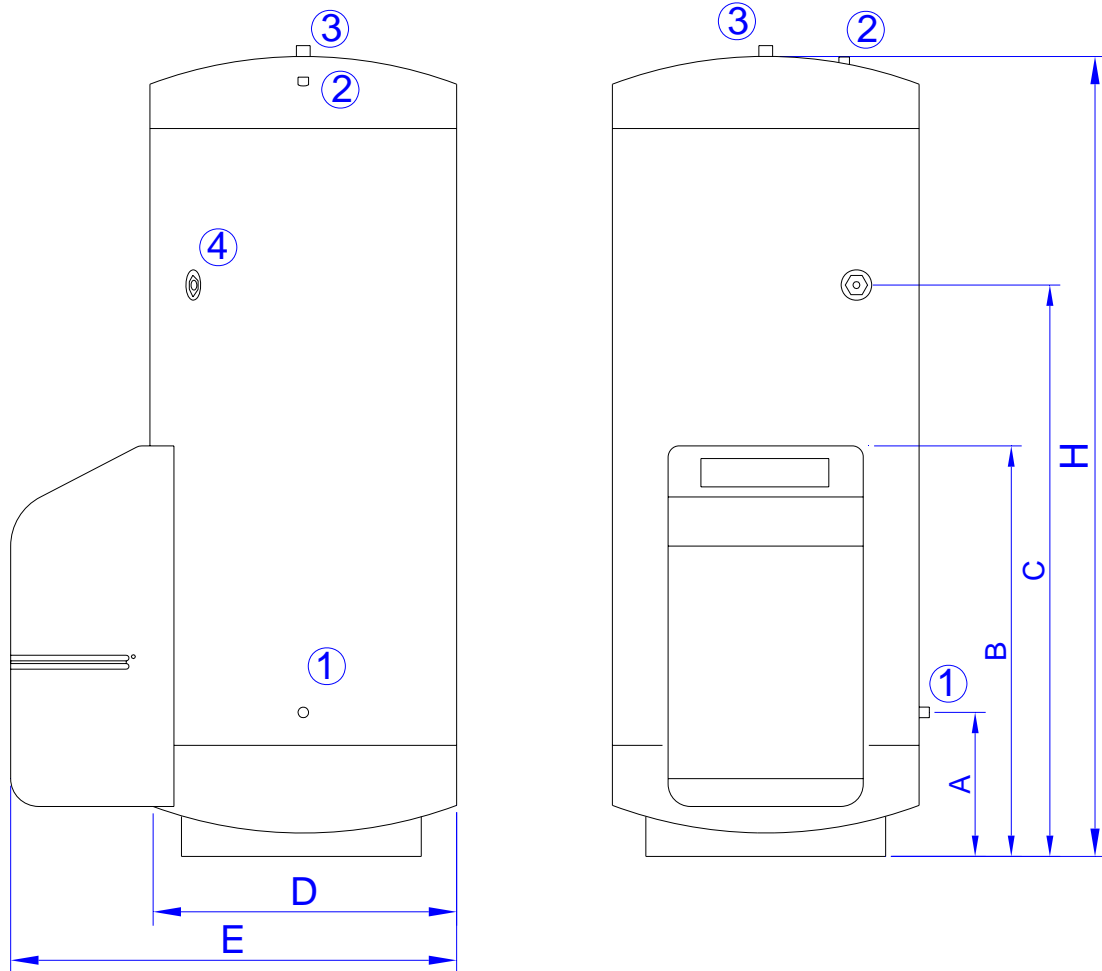

- 1- Cold water inlet
- 2- Recirculation
- 3- Hot water outlet
- 4- Magnesium anode

A	B	C	D	E	H	1	2	3	4
mm					inches				
260	750	1280	550	800	1650	3/4"	1/2"	3/4"	1' 1/4"

Eco 300esm

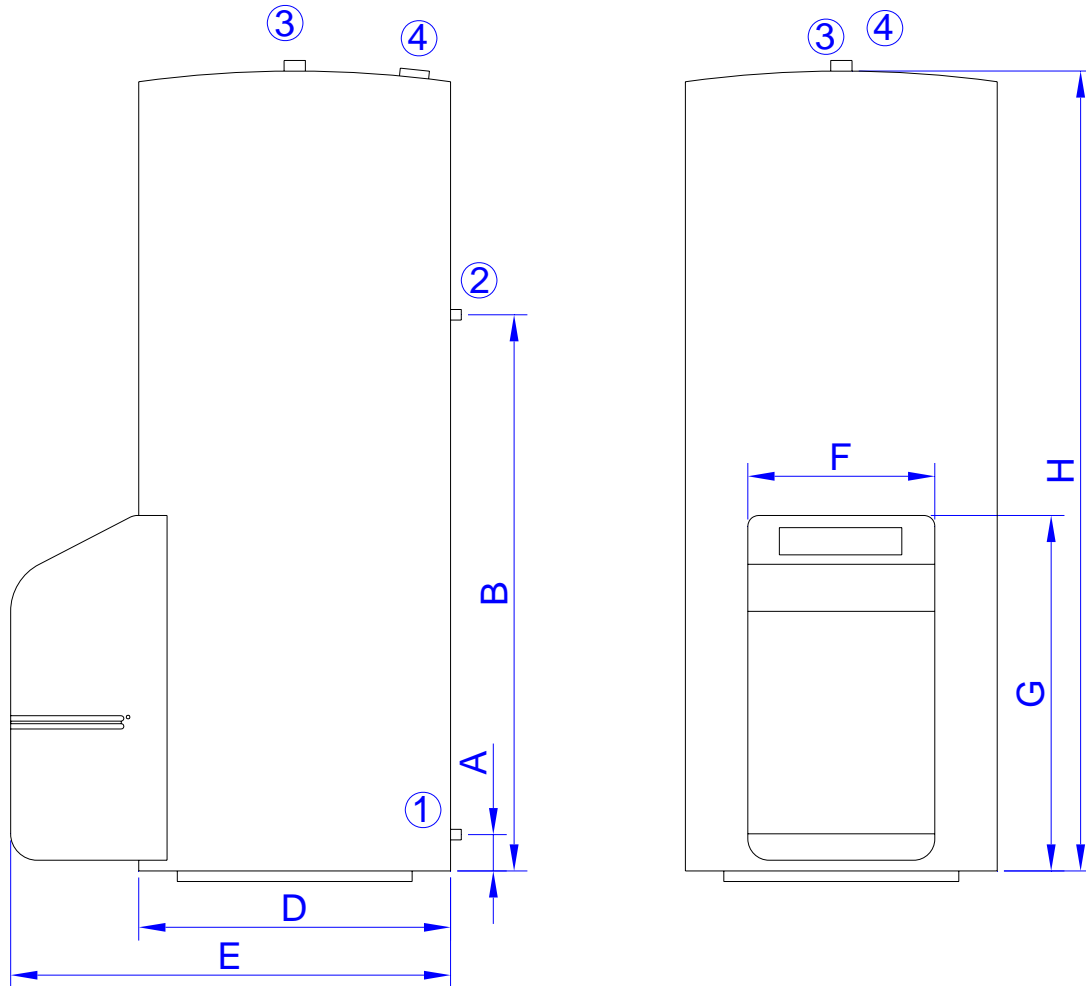

- 1- Cold water inlet
- 2- Recirculation
- 3- Hot water outlet
- 4- Magnesium anode

A	B	D	E	F	G	H	1	2	3	4
mm							inches			
90	770	680	930	350	850	1580	1"	1"	1"	5/4"

Eco 200p (Wall Hanging)

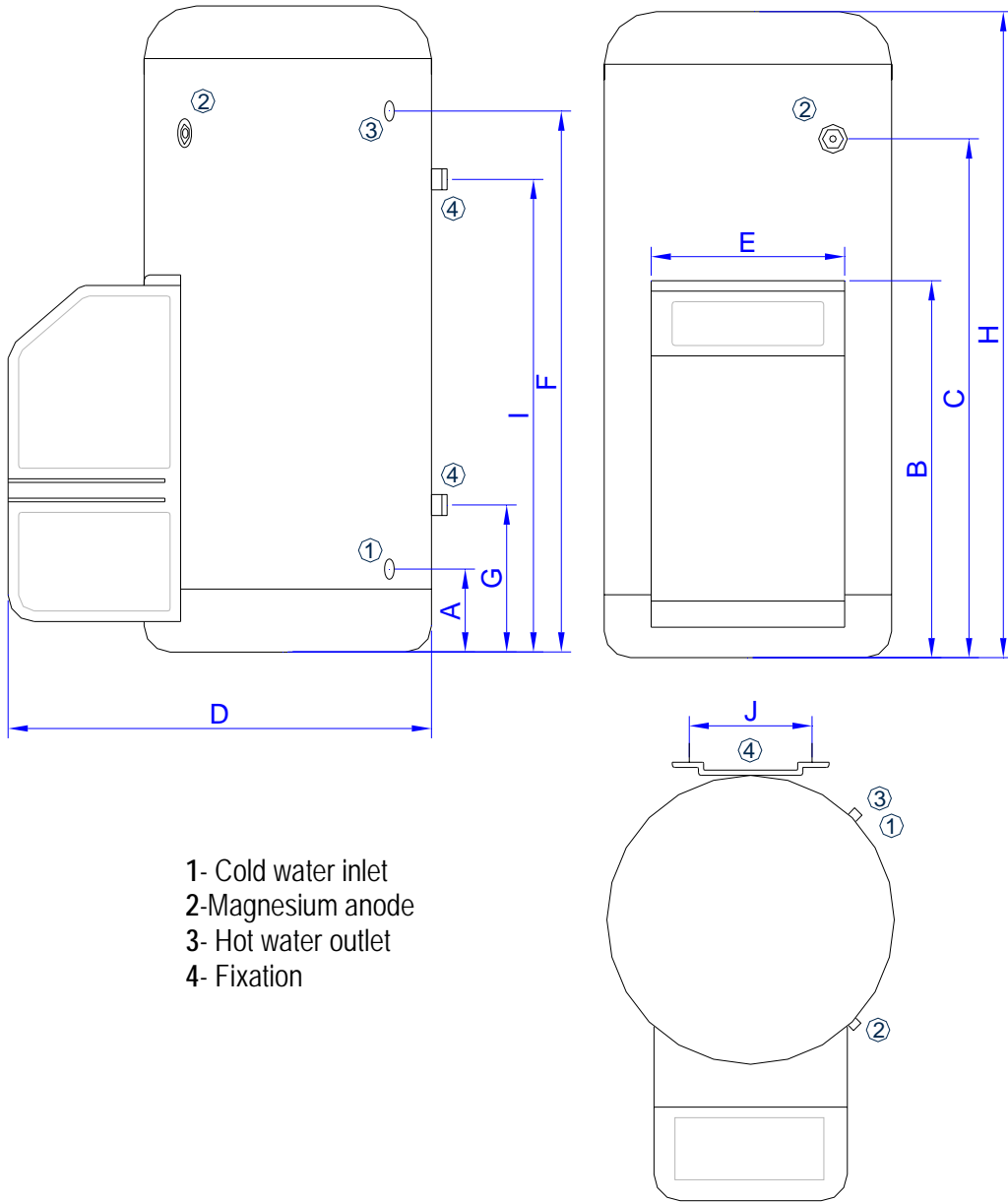

- 1- Cold water inlet
- 2- Magnesium anode
- 3- Hot water outlet
- 4- Fixation

A	B	C	D	E	F	G	H	I	J	1	2	3	4
mm										inches			
180	750	900	800	370	920	280	1250	1030	235	3/4"	1"1/4	3/4"	Fixation

Electrical Schematic

Eco 250esm / 300esm / 280i / 280p

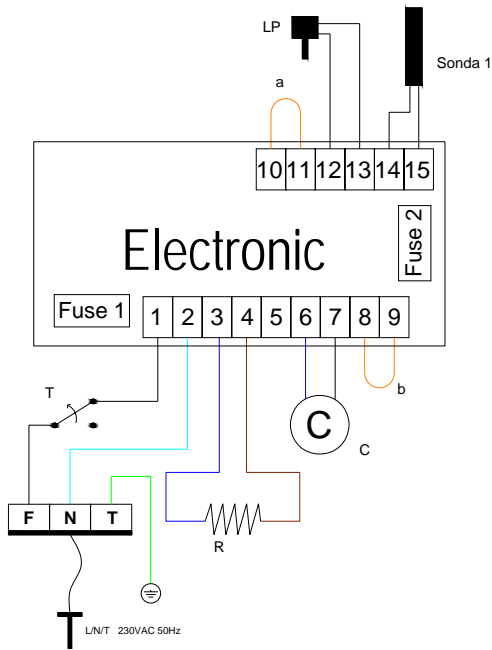

- T – Safety Thermostat (75°C)
- C – Compressor
- R – Resistance
- LP – Low Pressure Switch
- Sonda1 – Temperature probe
- a,b – Extra contacts
- Fuse 1 – General fuse
- Fuse2 – Compressor fuse

Guarantee

This guarantee covers all defects to the confirmed materials, excluding the payment of any type of personal damage indemnity caused directly or indirectly by the materials.

The periods indicated below start from the purchase date of the apparatus, 6 months at the latest from the leaving date from our storage warehouses.

Hot Water Cylinder	Solar Panel	Thermodynamic Block
3 Years: Stainless Steel		
2 Years: Enamelled	5 Years	2 Years
Manufacturer Guaranteed	Against Corrosion	

Guarantee Exclusions

The guarantee ceases to be effective when the apparatus is no longer connected, used or assembled in accordance with manufacturer instructions, or if there has been any form of intervention by unauthorised technicians, has the appearance of modifications and/or if the series number appears to have been removed or erased.

Further exclusions from guarantee:

- Hot water cylinders have been operating in water with the following indexes:
 - Active chlorine > 0.2 ppm
 - PH < 6 (Sorensen scale at 25° C).
 - All water has a value greater than the VMA, by decree – law 74/90
- Parts are subject to natural wear and tear – levers, switches, resistances, programmers, thermostats, etc.
- Breakdown due to incorrect handling, electrical discharges, flooding, moisture or by improper use of the apparatus.
- The guarantee lapses if it is transferred to another owner, even if within the guarantee period.
- The guarantee lapses if this certificate is incorrectly filled in, if it is violated or if it is returned after more than 15 days have passed since the purchase date of the apparatus.

ATTENTION: Technical assistance costs, even within the guarantee period, shall be supported by the customer (Km and assistance time). In cases where there is no justifiable breakdown and subsequent need for technical assistance, the client will pay for lost technical assistance time.

NOTE: This sheet should remain with the manual, for the customer. The following sheet shall be completed and must be returned to Energie est, Lda. otherwise the guarantee will not be valid.

Date : ____/____/____

Installer Stamp and Signature :