

Split Heat Pump with Supplementary Coil



Specifications		Aquapura Split 250ix	Aquapura Split 300ix
Nominal Capacity	l	250	300
Thermal Power (Med/Max)	W	1920/3200	1920/3200
Power Consumption (Med/Max)	W	600/1000	600/1000
Temperature (Factory Setpoint)	°C	52	52
Maximum Temperature	°C	80	80
Max. Amount of water at 40°C in a run (St.)	l	325	370
Maximum Operation Pressure	bar	6	6
Sound Power Level	dB	33	33
Liquid Line	Pol.	1/4	1/4
Suction Line	Pol.	3/8	3/8
Electrical back-up power	W	1500	1500
Gross Weight of Cylinder (St.)	Kg	69	81
Electrical Supply	V/Hz	230/50	230/50

**LOW-COST EFFICIENT SOLUTION
SILENCE AT HOME**

COP 3,5



Technical drawing

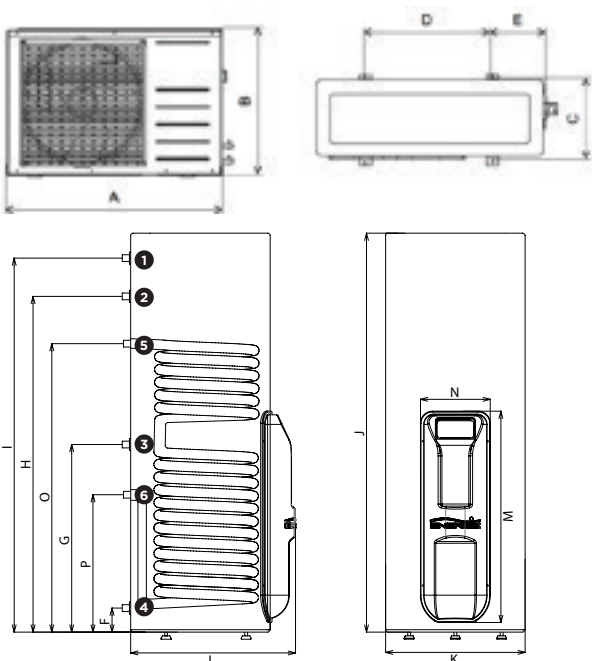

With flares valves on the split unit and on the cylinder
With dielectric threads for water connections

Dimensions	250ix	300ix
F	74	74
G	815	815
H	1326	1593
I	1451	1671
J	1530	1740
K	580	580
L	685	685
M	879	879
N	290	290
O	1251	1251
P	681	681

Dimensions	Outdoor Unit
A	700
B	525
C	250
D	458
E	120

1 (Hot water)	3/4" Male
2 (PT valve)	1/2" Female
3 (Recirculation)	3/4" Male
4 (Cold water)	3/4" Male
5 (Coil Inlet)	1" Male
6 (Coil Outlet)	1" Male