

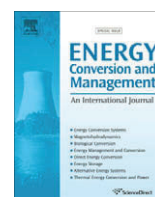

Contents lists available at ScienceDirect

Energy Conversion and Management

journal homepage: www.elsevier.com/locate/enconman

Performance analysis of a grid connected photovoltaic park on the island of Crete

Emmanuel Kymakis*, Sofoklis Kalykakis, Thales M. Papazoglou

Electrical Engineering Department, Technological Educational Institute (TEI) of Crete, Estavromenos, P.B. 1939, Heraklion, GR-71004 Crete, Greece

ARTICLE INFO

Article history:

Received 6 May 2008

Accepted 3 December 2008

Available online 9 January 2009

Keywords:

Photovoltaic

Performance

Final yield

Crete

ABSTRACT

The favorable climate conditions of the island of Crete and the recent legislation for utilization of renewable energy sources provide a substantial incentive for installation of photovoltaic power plants. In this paper, the grid connected photovoltaic park of C. Rokas SA in Sitia, Crete, is presented, and its performance is evaluated. The photovoltaic park has a peak power of 171.36 kW_p and has been in operation since 2002. The park is suitably monitored during 1 year, and the performance ratio and the various power losses (temperature, soiling, internal, network, power electronics, grid availability and interconnection) are calculated. The PV park supplied 229 MW h to the grid during 2007, ranging from 335.48 to 869.68 kW h. The final yield (Y_F) ranged from 1.96 to 5.07 h/d, and the performance ratio (PR) ranged from 58 to 73%, giving an annual PR of 67.36%.

© 2008 Elsevier Ltd. All rights reserved.

1. Introduction

The Greek photovoltaic market is rapidly growing, attracting an enormous investment interest due to the recently launched feed-in tariff (RES law) [1] guarantying a price of 0.4–0.5 € per kW h for a 20 year period and a supplementary investment subsidy by 20–40%. Therefore, the payback time of an investment in Greece with very high insolation may be the lowest in all Europe. To benefit from this growth, the actual performance analysis of the largest installed photovoltaic (PV) park in Greece, and especially in the island of Crete, with one of the highest insolation values across Europe, is of great importance in order to support the investor's expectations for system performance and the associated economic return. Furthermore, the performance evaluation with real data can allow the detection of operational problems, facilitate the comparison of systems that may differ with respect to design and evaluate the interaction of the park with the local grid, which is of high significance in a large autonomous electric system, such as the Cretan one [2,3].

In this paper, the performance of the grid connected C. Rokas SA PV park in Sitia, Crete, for the year 2007 has been analysed on hourly, daily and monthly bases. The derived parameters included reference yield, array yield, final yield of array, capture losses, system losses and performance ratio.

2. Photovoltaic park

The pilot PV park is located in Xirolimni, Sitia, Crete. The PV park is the largest operating PV park in Greece with an installed capacity of 171.36 kW_p, grid connected with a 20 kV TEP trans-

mission line, covering a total surface area of 3784 m² with an active area of 1142.4 m². The park is comprised of 1428 MSX 120 Solarex (now BP Solar) polycrystalline silicon PV modules. The PV modules are arranged in 120 parallel strings, with 12 modules in each, and connected to 60 Sunny Boy SB2500 inverters installed on the supporting structure, plus connection boxes, irradiance and temperature measurement instrumentation and data logging system. The inverters are tied to the national grid via a 0.4/20 kV transformer and an electrical energy meter. The PV system is mounted on a stainless steel support structure facing south and tilted at 30°. Such a tilt angle was chosen to maximise yearly energy production. Fig. 1 shows the PV park, and Fig. 2 shows a schematic block circuit diagram of the system's electrical connection.

3. System analysis

The PV park system was fully monitored to assess the performance of the system with the local power grid. To evaluate the PV park performance, the final yield (Y_F), the reference yield (Y_R), the performance ratio (PR) and the capacity factor (CF) were calculated as defined by the IEC Standard 61724 [4].

The final yield is defined as the annual, monthly or daily net AC energy output of the system divided by the peak power of the installed PV array at standard test conditions (STC) of 1000 W/m² solar irradiance and 25 °C cell temperature

$$Y_F = \frac{E \text{ [kW h}_{AC}]}{P_r \text{ [kW}_{DC}]} \quad (1)$$

The reference yield is the total in-plane solar insolation H_t (kW h/m²) divided by the array reference irradiance (1 kW/m²); therefore, the reference yield is the number of peak sun-hours

* Corresponding author. Tel.: +30 2810 379895; fax: +30 2810 379845.
E-mail address: kymakis@stef.teiher.gr (E. Kymakis).



Fig. 1. View of the C. Rokas SA Photovoltaic Park. The PV modules are tilted at 30° and oriented south (the adjacent wind park in the background).

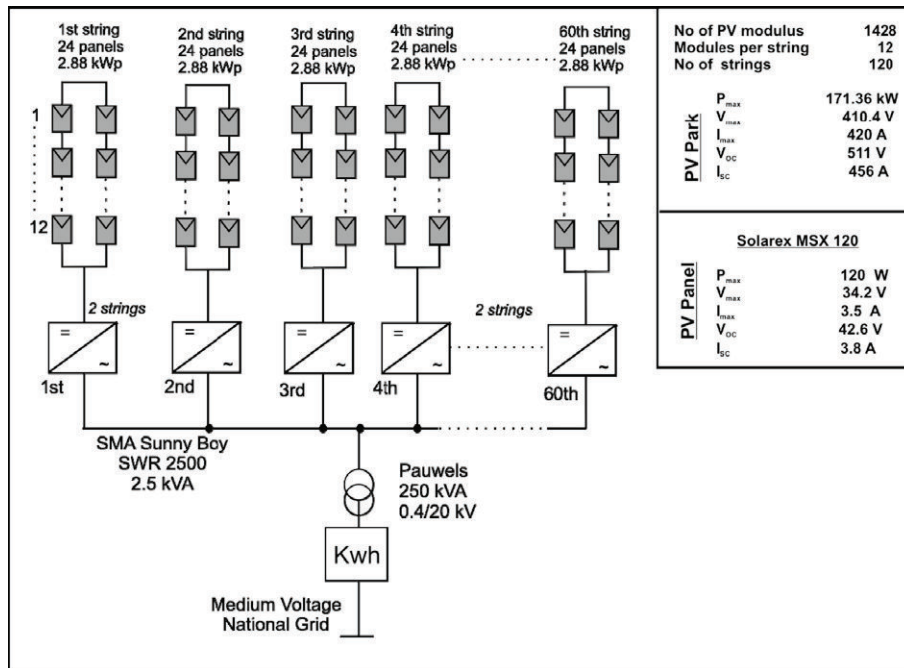

Fig. 2. Schematic block circuit diagram of the PV system.

$$Y_R = \frac{H_t \text{ [kW h/m}^2\text{]}}{1 \text{ kW/m}^2} \quad (2)$$

The performance ratio is the final yield divided by the reference yield; it represents the total losses in the system when converting from name plate DC rating to AC output. The typical losses of a PV park include losses due to panel degradation (η_{deg}), temperature (η_{tem}), soiling (η_{soil}), internal network (η_{net}), inverter (η_{inv}), transformer (η_{tr}) and system availability and grid connection network (η_{ppc}). Therefore, the PR can be expressed as

$$PR = \frac{Y_F}{Y_R} = \eta_{deg} \cdot \eta_{tem} \cdot \eta_{soil} \cdot \eta_{net} \cdot \eta_{inv} \cdot \eta_{tran} \cdot \eta_{ppc} \quad (3)$$

While the array yield (Y_A) is defined as the annual or daily energy output of the PV array divided by the peak power of the installed PV, the system losses (L_S) are gained from the inverter and transformer conversion losses, and the array capture losses (L_C) are due to the PV array losses

$$Y_A = \frac{E_A}{P_R} \quad (4)$$

$$L_C = Y_R - Y_A \quad (5)$$

$$L_S = Y_A - Y_F \quad (6)$$

Finally, the capacity factor (CF) is defined as the ratio of the actual annual energy output to the amount of energy the PV park would

generate if it operated at full rated power (P_r) for 24 h per day for a year

$$CF = \frac{Y_F}{8760} = \frac{E}{P_r * 8760} = \frac{H_t \cdot PR}{P_r * 8760} \quad (7)$$

The incident global irradiance in the array plane, the ambient temperature, the DC array output power and the PV park AC output power were measured every 10 min and stored in the logger system. The monthly AC output energy at the grid connection point was also given by the Greek PPC. Complete operation data from the logger for the year 2007 was averaged for every 10 min during a typical day per month. Fig. 3 shows the monthly averaged total in-plane insolation together with the monthly ambient temperature averaged over the daytime hours.

The highest value of total in-plane insolation was in July with 224.66 kW h/m² and the lowest in December was 92.35 kW h/m². The annual insolation was 1984.38 kW h/m², and the mean ambi-

ent temperature was 16.46 °C. The PV park generated 229 MW h in 2007, ranging from 10.4 (December) to 26.96 MW h (July). Fig. 4 shows the monthly averaged daily final yield, array capture losses and system losses. The monthly averaged daily array yield ranged from 2.25 (December) to 6.6 h/d (July), and the final yield ranged from 1.95 to 5.07 h/d. The average annual final yield and the reference yield were 1336.6 and 1984 h, respectively. The monthly averaged daily array losses ranged from 0.54 (November) to 1.38 h/d (September), and the system losses ranged from 0.29 (December) to 1.52 h/d (July). The performance ratio was distributed within the range of 58–73%, and the annual mean value was 67.36%.

The annual final yield of 1336.6 kW h/kW p for the PV park is significantly higher than that of PV parks operated in Germany [5] and similar to that of parks operated in Southern Spain [6], demonstrating the huge potential of an investment in the island of Crete. The average annual capacity factor was 15.26%.

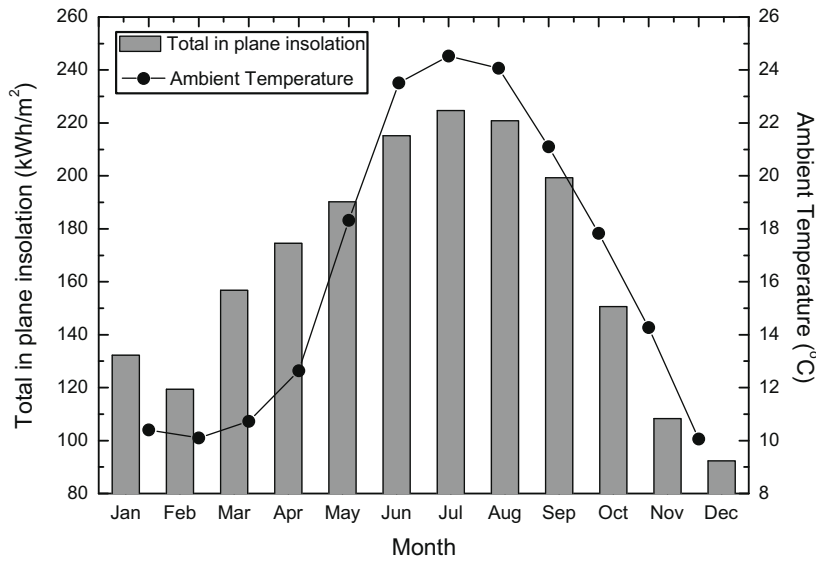

Fig. 3. Monthly averaged total in-plane insolation and ambient temperature averaged during the daytime hours over the year 2007.

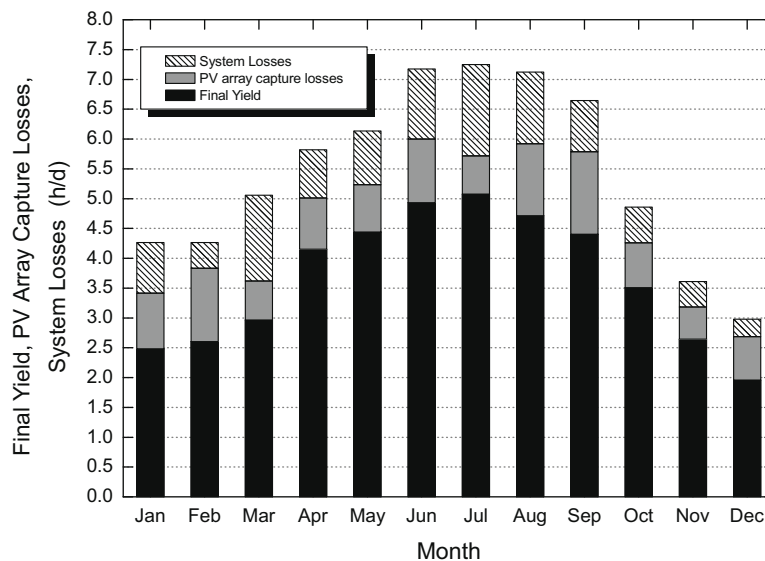

Fig. 4. Monthly averaged daily final yield, PV array capture losses and system losses.

The methodology followed to calculate analytically the various losses of the PV park can be described as follows; The in-plane solar radiation, the ambient daytime temperature, the array DC power and the park AC output power are averaged with a 10 min frequency during a typical day per month. The nominal instantaneous array DC power per 10 min and the total array annual output energy are calculated using the solar radiation data and the technical specifications of the photovoltaic panels used. Then, the real array output power is simulated gradually by adding the various losses of the array; the degradation modulus, the temperature and the soiling losses. The same route is followed for calculation of the interconnection, inverter and transformer losses by correlating the real array power output with the PV park power output with a 10 min frequency. This method gives a realistic estimate, since the various losses are interrelated and directly linked with

the instantaneous real power output of the PV panels and the PV park.

The efficiency of a PV panel depends on the operation temperature and the power density of the solar radiation. As the temperature of the PV panels increases, the efficiency decreases linearly, since the peak power of the PV panels refers to STC conditions. In different temperatures, the output power of the PV panels depends on the difference of the panel temperature and the STC temperature ($T_c - T_{STC}$) and the power density (G) of the incident solar radiation. The PV module monthly operating temperature and the ambient temperature measured during daylight hours over the monitored period are shown in Fig. 5.

In summer, the monthly average hourly PV module temperature varied within 22–31 °C, and the ambient temperature ranged between 13 °C and 18 °C. In winter, the average hourly PV module

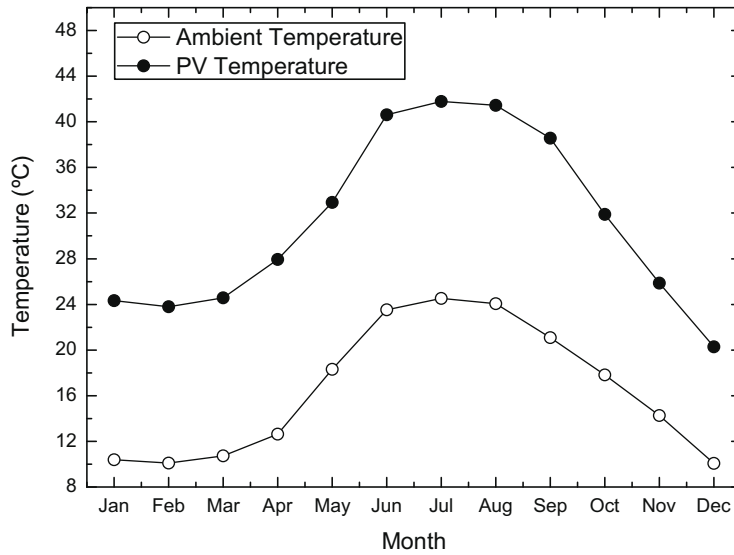

Fig. 5. Monthly averaged hourly ambient air and PV module temperature measured during daylight hours for 2007.

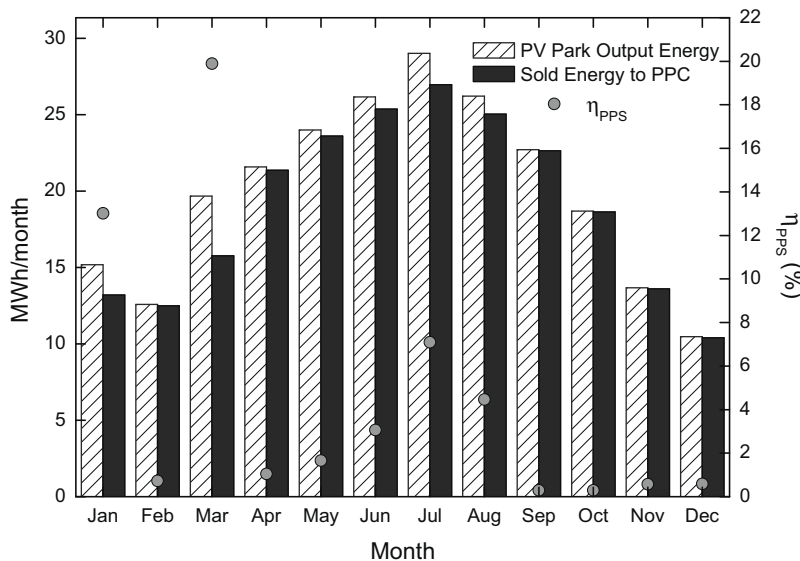

Fig. 6. Monthly PV park output energy, monthly sold energy to PPC, and availability and national grid connections losses coefficient (η_{PPC}).

temperature varied from 10 °C to 12 °C, and the ambient temperature ranged between 6 °C and 8 °C.

The temperature losses coefficient (η_{tem}) can be calculated as

$$\eta_{tem} = 1 + \beta(T_c - 25) \quad (8)$$

where β is the temperature factor of the PV panel. The PV cell temperature (T_c) is correlated with the air temperature (T_a) as follows:

$$T_c = T_a + \frac{G}{G_{NOCT}}(T_{NOCT} - 20) = T_a + \frac{G}{800}(T_{NOCT} - 20) \quad (9)$$

where NOCT is the nominal temperature operational cell temperature and G is the power density at the particular time. The temperature losses coefficients were calculated with a 10 min frequency, and the annual losses were summed to 7.12%.

The PV panels under continuous operation eventually become covered with a fine layer of dirt and dust, decreasing the amount of light reaching each cell. The amount of power loss due to soiling (η_{soil}) depends on the type of dust (local agricultural activities), the length of time since the last rainfall and the cleaning maintenance schedule. For the specific PV park, the monthly coefficients were empirically estimated based on the PVUSA study [7] and the rainfall data of the site. **The soiling losses were 4–5% during the winter and 6–7% during the summer period, resulting in annual losses at 5.86%.**

By adding the temperature and soiling losses to the nominal array power output without losses ($P_{PV} [kW] = \frac{P_r [kW p] \cdot G [kW/m^2]}{1 [kW/m^2]}$), a 5% mismatch compared with the real recorded output power was observed. This mismatch can be attributed to the PV panel degradation losses (η_{deg}) during ageing, since the PV park is in full operation since 2002. This is in full agreement with experimental studies and manufacturers declarations and warranties, whereas the initial power declarations lie at 5% with a lifetime maximum of 20% [8].

The inverter (DC to AC) conversion losses were calculated with a 10 min frequency by subtracting the array DC output power from the AC output power and by normalizing the DC wiring and inter-connection losses ($\eta_{net} = 6\%$) and the transformer losses ($\eta_{tr} = 2\%$). Therefore, the calculated losses with inverter losses (η_{inv}) are summed to 7.84%. Finally, the monthly availability and national grid connections losses (η_{ppc}) were calculated as the ratio of the sold energy to the PPC divided by the AC overall output energy of the park and are shown in Fig. 6.

The availability and grid connection losses (η_{ppc}) range from 0.3 (October and November) to 19.9% (March), with an annual average of 4.54%. The losses are very low (<1%) in February, April, September, October and December; there is an increase from May until July, while for January and March, the losses are extremely high. The data cannot be explained at the present time, since there is no data for the grid off periods. Nevertheless, it can be postulated

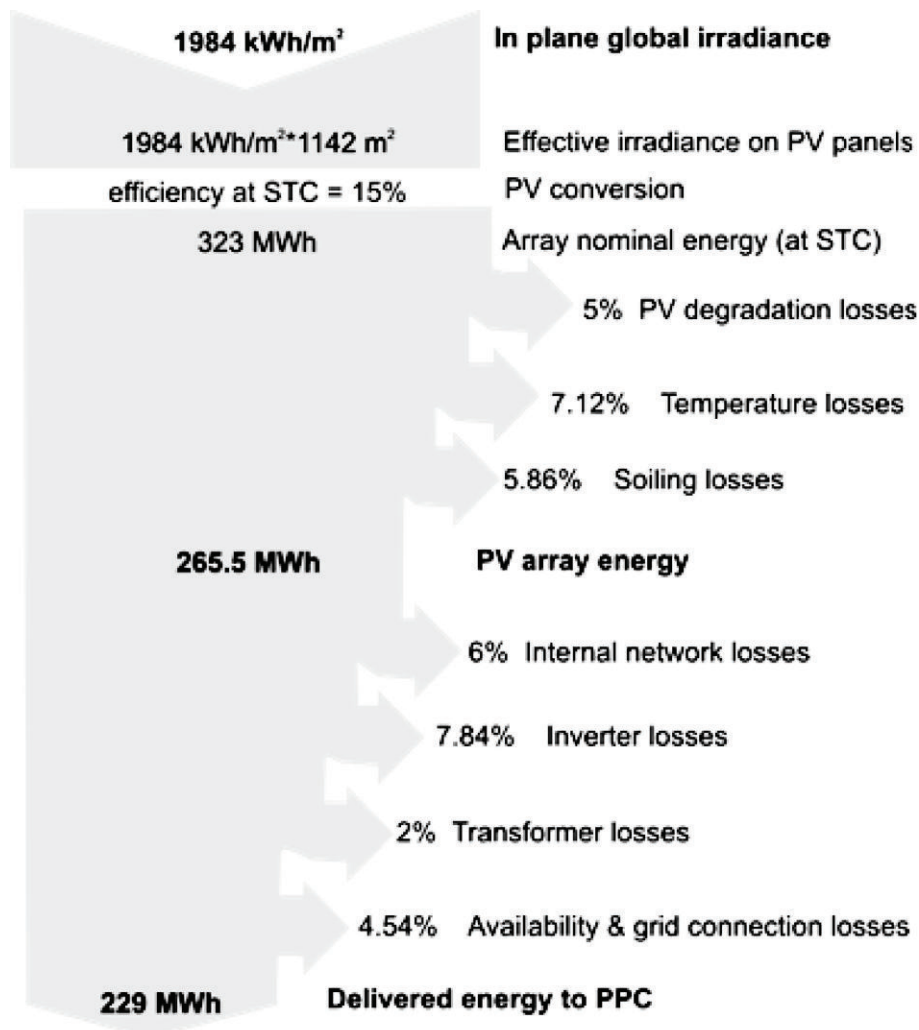

Fig. 7. Sankey diagram of estimated losses in the PV park, the parameters in bold are derived from the real measurements raw data analysis.

that in January and March, there is a significant period where the grid rejects the power input from the park. This is an important feature, taking into account that Crete's autonomous electrical system is the largest one in Greece with the highest rate of increase nation-wide in energy and power demand [2].

The various annual losses of the PV Park can be summarized in the Sankey diagram of Fig. 7.

4. Conclusions

The first long term monitoring and performance analysis of a grid connected PV system in the island of Crete has been investigated. The following conclusions can be drawn:

- Average annual PV park energy output in 2007 is 1336.4 kW h/kW p.
- Average annual performance ratio of the park is 67.36%.
- The average annual capacity factor is 15.26%.

As a conclusion, the integration of this renewable energy generation with the transmission network is considered satisfactory. This is in addition to the large scale integration of wind power generation in the Cretan system, providing 13% of the total electricity generation on an annual basis, having thus demonstrated a concrete step of integration of renewable and distributed generation in the system.

Acknowledgements

The authors would like to acknowledge C. Rokas S.A. for giving access to the PV park SCADA data and for fruitful discussion. We particularly would like to thank Mr. E. Kalyvas and Mr. E. Spyridakis.

References

- [1] Greek Parliament Law 3468/2006, Government Gazette A' 129/27.06.2006, Generation of electricity using renewable energy sources and high-efficiency generation of electricity and heat and miscellaneous provisions.
- [2] Svllignakis J, Papazoglu TM. Study of impact on crete system operation of the Atherinolakos power plant. In: Proceedings of the 41st international universities power engineering conference, vol. 2; 2006. p. 482–5.
- [3] Hatziaargyriou ND, Tsikalakis A, Androusos A. Status of distributed generation in the Greek islands. In: IEEE power engineering society general meeting, PES. Art. no. 1709075; 2006.
- [4] IEC. Photovoltaic system performance monitoring—guidelines for measurement, data exchange and analysis. IEC standard 61724. Geneva, Switzerland; 1998.
- [5] Decker B, Jahn U. Performance of 170 grid connected PV plants in Northern Germany—analysis of yields and optimization potentials. Sol Energy 1997;59:127–33.
- [6] Sidrach-de-Cardona M, Mora Lopez II. Performance analysis of a grid-connected photovoltaic system. Energy 1999;24(2):93–102.
- [7] Townsend TU, Hutchinson PA. Soiling analysis at PVUSA. In: Proc ASES-2000. Madison (WI); 2000.
- [8] Dunlop ED. Lifetime performance of crystalline silicon PV modules. In: Proceedings of 3rd world conference on photovoltaic energy conversion, vol. 3(12–16); 2003. p. 2927–30.