



Installation and Operation Guide

Crystalline Solar Modules

Bosch Solar Module c-Si M48 EU | Bosch Solar Module c-Si M60 EU I
Bosch Solar Module c-Si M60 S EU | Bosch Solar Module c-Si P60 EU I



BOSCH

Invented for life

en Operating instructions

Table of Contents

1	Introduction	2
2	Safety guidelines	3
3	Positioning guidelines	4
4	Installation guidelines	5
5	Circuitry guidelines	8
6	Electrical connector	9
7	Grounding	10
8	Maintenance and upkeep	10
9	Disposal	10
10	Storage and transport	11

1 Introduction

Please read this installation and operation guide completely and carefully before you transport, install and operate the solar modules! It contains (among other information) important safety information which you must know. When solar modules are used without observing all instructions in this guide, all warranty and guarantee claims towards us shall lapse. We reserve the right to update the information in this guide without prior notice.

The installation, setup and commissioning of solar modules requires a high level of expertise and experience, and therefore must be performed solely by specialists (e.g. a specialist electrician) who can verify the successful completion of suitable training.

2 Safety guidelines

The setup and commissioning of the electrical system may only be performed by a specialist electrician in observance of the following guidelines, since improper performance of this work can lead to damage and injury. When performing work on solar generators – primarily on roofs – suitable safety precautions (e.g. fall arresting devices) must be used. The regulations set forth by Employers' Liability Insurance Associations must absolutely be observed. For your own safety and to safeguard your solar module, please observe the following **safety guidelines**:



Important Notice!



- ▶ During the setup and maintenance of solar modules, the valid regulations and safety guidelines for the installation of electrical devices and systems, as well as the regulations set forth by the competent energy supply company for the parallel grid operation of solar power systems.
- ▶ Prior to setup, the solar module must be inspected for mechanical soundness. **Damaged solar modules** (e.g. modules with broken glass, damage to the insulation film at the reverse) **may not be set up**. Damage to the insulation film at the reverse has severe potential consequences (delamination, endangerment of life and health).
- ▶ Definitely align the solar module so as to avoid a shadowing effect (even to a temporary or partial extent: e.g. due to roof dormers, trees), since this can lead to damage in the solar modules (e.g. formation of „hot spots“), failure of the PV generator and loss of output.
- ▶ The serial connection of the modules (addition of the module voltages) may result in voltages above the safety extralow voltage of 120 V DC!
- ▶ Application class of the modules in accordance with IEC 61730: A
- ▶ Even when the light intensity is low, one must reckon with the full atrest voltage of the modules – that is to say, in the course of setup, one must always exercise the greatest caution with regard to electrical faults (e.g. short circuits).
- ▶ The separation of conductors which carry direct current can lead to light arcs. Therefore, prior to performing any work on the solar system – particularly prior to separating the plug connectors in the direct-current circuit – it is essential to disconnect the frequency inverter from the alternating-current grid.
- ▶ For roof-mounted systems, the modules must be attached above a fire-resistant surface.
- ▶ Solar modules may not be installed near easily-flammable substances, gases or vapors.
- ▶ The guidelines on fires in electrical systems (e.g. VDI 3819) apply hereto.
- ▶ The maximum permissible totalsystem voltage for the frequency inverter may never be exceeded. In addition, due to the negative temperature coefficient of the solar modules, the atrest voltage of the total system at the minimum permissible temperature must also be calculated (see data sheet and module type sign).
- ▶ The solar module is to be treated as a glass product and may therefore not be used or walked on under any circumstances in the transport container or used as a placement area (e.g. for toolboxes), since this can lead to visible or even invisible damage (e.g. microcracks in the cells and with that, a premature drop in output – among other faults).
- ▶ The module frames may not be drilled, nailed or welded to a contact surface.
- ▶ The solar modules may not be held or transported by their connector cables or by the connector socket.
- ▶ Solar modules may never be left standing freely or unsecured.
- ▶ The safety guidelines set forth by the manufacturers of other components of the solar system must be followed.
- ▶ The drainage drill holes in hollowchamber frames may not be covered.
- ▶ Solar modules made by Bosch Solar Energy are not regulated construction products in the context of the DIBt (Deutsches Institut für Bautechnik – German Institute for Construction Engineering) and may not be used as overhead glazing.

3 Positioning guidelines

In order to achieve the highest-possible annual energy yield, we recommend positioning the module so as to fulfill the following criteria:

- ▶ Definitely align the solar module so as to avoid a shadowing effect (even to a temporary or partial extent: e.g. due to roof dormers, trees), since this can lead to damage in the solar modules (e.g. formation of „hot spots“), failure of the PV generator and loss of output.
- ▶ Align the front of the solar module to the south.
- ▶ Select the angle of inclination according to the local and structural factors ($30^\circ \pm 15^\circ$). You will find specific data on optimum module positions in the pertinent specialized literature. The calculation of the angle of inclination can be based on the following formula: angle of inclination = latitude of the positioning locality – 20°
- ▶ All modules of a photovoltaic generator are to be aligned at the same angle (horizontal as well as vertical). In the event of angle deviations, separate frequency converters are to be designated.
- ▶ In order to ensure sufficient selfcleaning, the angle of inclination must amount to at least 10° .
- ▶ For optimized selfcleaning, a 15° minimum angle of inclination is recommended.
- ▶ Always ensure that the reverse side of the module is well ventilated.
- ▶ To avoid increased strain of the modules due to wind load, it is necessary to observe minimum distances from building boundaries according to DIN 1055-4.
- ▶ A concentration of sunlight on the modules via mirrors or lenses is prohibited.
- ▶ Avoid contact with salty water!
- ▶ The crystalline solar modules made by Bosch Solar Energy have been tested in accordance with the following norms for their response to contact with salty air:
 - IEC 61701: 1995
 - DIN EN 61701: 2000-08
 - IEC 60068-2-52.

Please observe the test conditions indicated in the norms when using the modules in salty air.

4 Installation guidelines



Important Notice!



- ▶ Definitely align the solar module so as to avoid a shadowing effect (even to a temporary or partial extent: e.g. due to roof dormers, trees), since this can lead to damage in the solar modules (e.g. formation of „hot spots“), failure of the PV generator and loss of output.
 - ▶ The additional loads which arise by way of the weight and the structural attachment of the PV system are to be included in the structural analysis of the overall construction.
 - ▶ Verifications of stability, deflection and load parameters are to be initiated by the constructor or the operator of the system.
 - ▶ Install the modules on a sufficiently-dimensioned, load-bearing and permanently corrosion-resistant substructure.
 - ▶ Observe the specifications for mounting areas according to **Illustrations 1 and 2**.
 - ▶ Attachment with clamps on the narrow sides of the solar module may not be performed.
 - ▶ The attachment of the solar module can be performed with clamps (or as an alternative, directly on the installation holes). When clamping systems are used, the clamp surface per attachment point on the module must amount to at least 400 mm².
 - ▶ Position of the installation drill holes in accordance with **Illustrations 3–6**
 - ▶ Per module, four non-corrosive screws and nuts (and grommets with min. 12 and max. 14mm exterior diameters) are to be used in accordance with **Table 1**.
- ▶ The modules must be attached flush to the substructure (without tension and deformation) at no less than four points.
 - ▶ The substructure and the solar module must have the same heat-expansion coefficient (aluminum).
 - ▶ Contact corrosion between the solar module and the substructure is to be avoided when different materials are used.
 - ▶ Attach the solar modules so that they with-stand all foreseeable loads and weather-induced influences.
 - ▶ Only use non-corrosive screws for the installation.
 - ▶ The solar module must be installed without mechanical tension and (to compensate material expansion due to temperature fluctuations) with a minimum gap of 5 mm to the next module.
 - ▶ Particularly in exposed locations, sufficient lightning protection is recommended.
 - ▶ Integration into existing lightning protection systems must occur in observance of the valid regulations.
 - ▶ Only install solar modules edgewise (or crosswise), with the connector socket facing upward.
 - ▶ In the course of elevation, it must be ensured that no rainwater or condensation water can run in the direction of the cable screw connections on the connector sockets.
 - ▶ The solar module may not stand in tail water or condensation water.

Module manufacturer code	Screw diameter
11, 13	M6
14, 17	M8

Table 1: Permissible fastening screws for direct installation

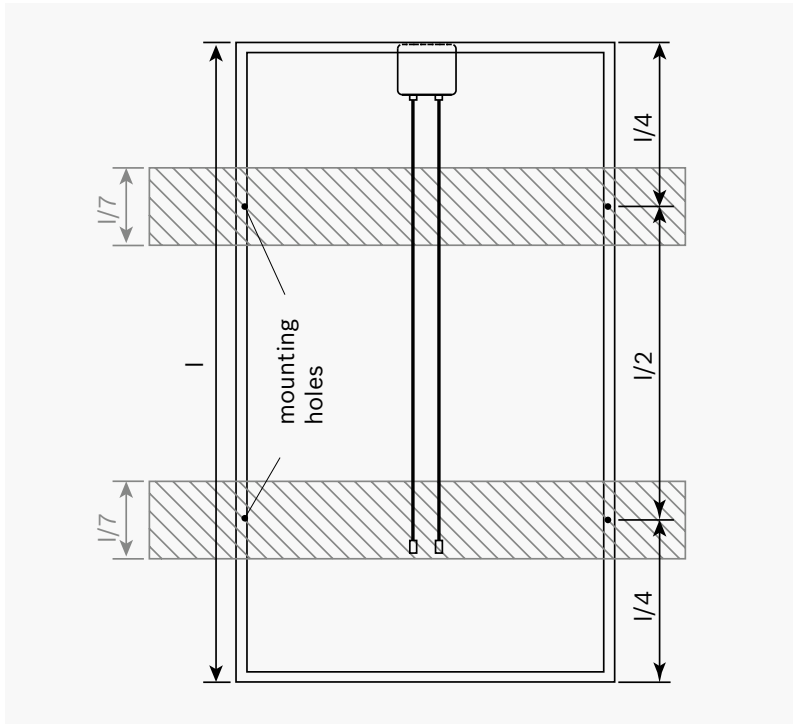

Figure 1: Mounting area, vertical

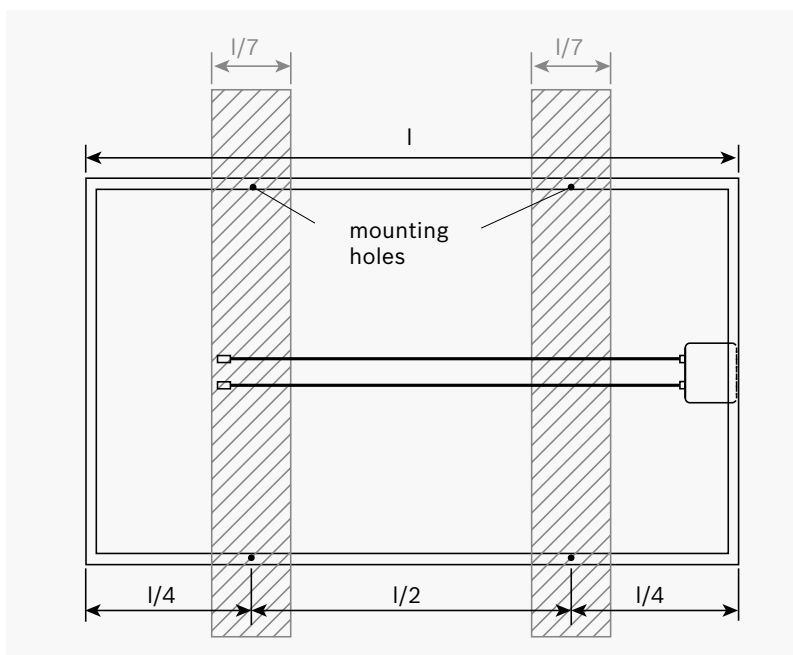

Figure 2: Mounting area, horizontal

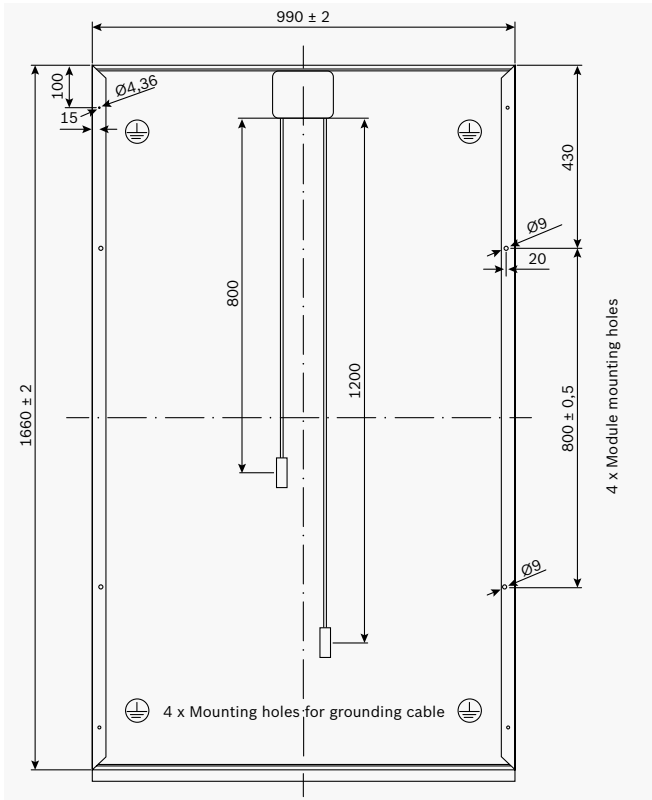

Figure 3: reverse side c-Si M60 and M60 S, Manufacturers 14 and 17

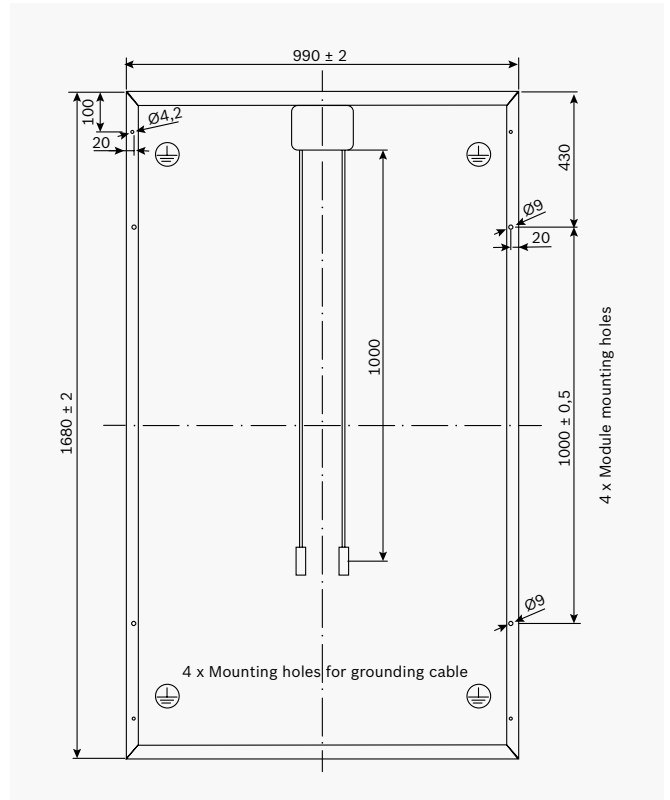

Figure 4: reverse side c-Si M60, Manufacturer 13

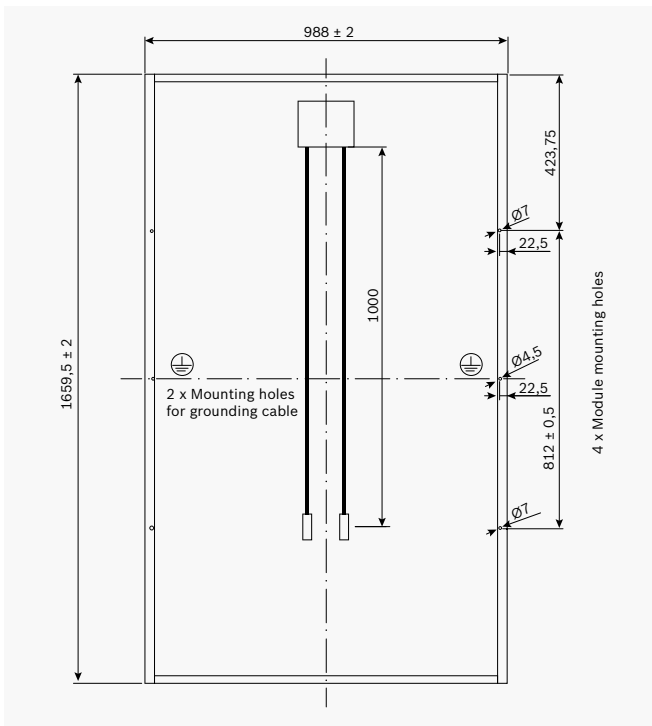

Figure 5: reverse side c-Si M60 and P60, Manufacturer 11

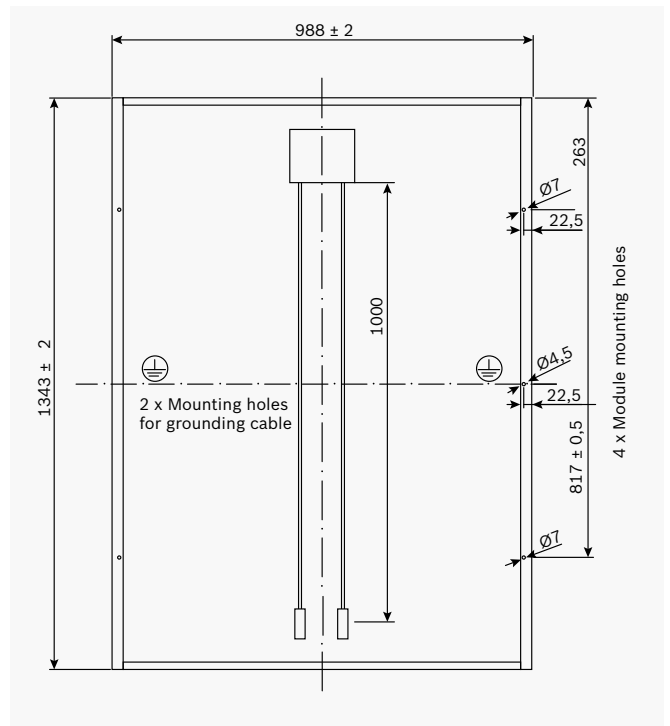

Figure 6: reverse side c-Si M48 and P48, Manufacturer 11

5 Circuitry guidelines

Only identical solar modules of the same type and engineering-power class may be switched. In this process, ensure that in the course of the serial switching of the modules, the maximum permissible system voltage is not exceeded. In this context, observe the temperature dependency of the module voltage for the solar modules, particularly since the module voltage rises when low temperatures prevail.

For the parallel switching of the modules, it must be ensured that always the same number of modules is serially switched to the stands to be switched parallel to these, and that suitable measures for surge protection

are taken (e.g. strand fuse). It must be ensured that the specified load capacity with regard to the reverse current IR (17 A at c-Si M60 and c-Si M48, 16 A at c-Si P60 and c-Si P48) is not exceeded.

Under standard conditions, a PV module can provide higher current and/or higher voltage than was specified under normed test conditions. To determine the voltage-rating values of structural components, the current-rating values of cables, the sizes of fuses and the rating of controls connected to the output of PV modules, the I_{sc} and U_{oc} values indicated on the module should therefore be multiplied by a safety factor of 1.25.

No more than two module strands can be switched parallel without a sufficiently-dimensioned strand fuse.

6 Electrical connector

The solar modules are designated for use in gridcoupled solar generators. When used for another purpose, the respective deviating technical particularities must be observed. The solar modules may only be installed by qualified specialized companies. In this context, the norms and regulations relevant to PV systems, such as VDE provisions, DIN norms, VDEW guidelines, the TAB of the competent system operators along with the rules set forth by the Employers' Liability Insurance Associations on accident prevention.

Particular reference is made once again to the following items:



Important Notice!



- ▶ Prior to the installation, the connector socket, cables and plug connectors are to be checked for damage and dirt.
- ▶ Do not install any damaged PV modules or any PV modules with dirty plug connectors.
- ▶ The solar modules (particularly the plug connectors and tools) must be dry during the installation.
- ▶ For the switching of module strings, only suitable (UV- and ozone-resistant) cables are to be used for outside installation.
- ▶ The cables must have a minimum cross-section of 4 mm², and the insulation must be approved for the maximum system atrest voltage.
- ▶ The cables are to be protected from damage by using e.g. a suitable fastener via cable clamps.
- ▶ The connector socket with cables connected at the plant may not be opened.
- ▶ The connector socket, the cable and the connector plug may not be cleaned or otherwise moistened with substances containing oil, grease or alcohol.
- ▶ The solar plugs installed by the plant may not be removed.
- ▶ In the course of the installation, one must ensure the tensile relief of the module connector cables.

- ▶ The connector cables are equipped with a high-quality plug-connector system for photovoltaics. The plugs are marked with the respective polarity, or the cables are designed in red for “plus” and blue for “minus”; see Table 2 and the data sheet.

Manufacturer	Module Version	Positive Pole	Negative Pole
11	EU xx011	Tyco, Neutral 6-1394461-2	Tyco, Minus 1394462-4
13	EU xx113	MC4, Plus PV-KST4	MC4, Minus PV-KBT4
14	EU xx014	MC3, Plus PV-KST3	MC3, Minus PV-KBT3
17	EU xx017	MC3, Plus PV-KST3	MC3, Minus PV-KBT3
17	EU xx117	MC4, Plus PV-KST4	MC4, Minus PV-KBT4

Table 2: Coding for connector plug¹

- ▶ When connecting the plug connectors and the modules (and when connecting the solar modules to the frequency inverter), always ensure that the polarity is correct. Reverse polarity leads to the destruction of important technical structural components such as frequency inverters, safety diodes or similar components.
- ▶ The connector cables are to be laid so as to ensure that the minimum bend radius of 60 mm is not undershot.
- ▶ In order to avoid the hazard of electric shocks, all frames of the solar modules as well as the support structure for potential equalization must be connected to the grounding so as to ensure good conductivity. We recommend grounding outside the building. In this process, observe the statutory regulations for your region, along with the recommendations issued by the frequency-inverter manufacturers and the insurance company.

Never plug in or unplug the plug contacts when under load current!

¹ EU XXXXX: Internal technology code

7 Grounding

Particularly in exposed locations, sufficient lightning protection is recommended. Integration into existing lightning-protection systems must occur in observance of current country-specific norms and regulations. The respective drill holes for grounding are marked on the reverse side of the module frame.

Please perform the following grounding measures:



Important Notice!



- ▶ Attachment of a fitting ring-cable socket (cable cross-section: min. 2.1 mm²).
- ▶ Use of a fitting fastening screw (minimum diameter: 4 mm), a self-cutting serrated washer, a spring washer and the fitting nut.
- ▶ Use of a fitting self-cutting screw. Two complete thread turns of a screw must interlock with the metal.
- ▶ Damaging contact corrosion can be avoided by using corrosion-resistant materials.
- ▶ Position of the grounding drill holes in accordance with **Illustrations 3–6**.

8 Maintenance and upkeep

Minimal maintenance and upkeep effort is required in order to maintain the optimum output of the solar module. In the interest of optimum system output, we recommend to inspect and/or work through the following items on a semiannual cycle:

- ▶ In the event of heavy or localized contamination (e.g. with bird droppings), it is recommended to clean the glass surface of the module with limefree water which matches the module temperature and a soft brush. No aggressive cleaning agents, acids or leaches may be used.
- ▶ The electrical and mechanical connectors must be checked for cleanliness, durability and sound condition. Any irregularities must be remedied immediately.
- ▶ Regular verification of the yields by the operator is recommended.

9 Disposal

Defective or old solar modules must be appropriately disposed of. These may not be disposed of in household waste.



Important Notice!



10 Storage and transport

The handling of modules requires great diligence. Therefore, caution is required when unpacking, transporting and temporarily storing these modules:



Important Notice!



- ▶ Do not set the modules down forcefully on hard ground or on the edges.
- ▶ Avoid bending during transport or when unpacking.
- ▶ Do not drop the modules.
- ▶ Do not place any objects on the modules.
- ▶ Do not handle the modules using sharp objects.
- ▶ In the course of storage and transport, it must be ensured that each solar module is sufficiently reinforced.

- ▶ The stacking of packaging units can cause damage to the solar modules and must definitely be avoided!
- ▶ The solar modules are to be secured against overturning!
- ▶ Layer pads must be used between the individual solar modules.

We recommend storing all solar modules in dry interior rooms and in the original packaging until their final installation.

When setting the modules down or transporting them to the immediate installation site (e.g. a roof), any damage to the module is to be avoided.

The modules may not be grasped and transported on a single frame component!

Installation guide last updated: 01.07.2011

Bosch Solar Energy AG

Wilhelm-Wolff-Straße 23
99099 Erfurt

Tel. +49 (0)361 2195-0
Fax +49 (0)361 2195-1133
www.bosch-solarenergy.de